

M6



Installation video
Operating video
Settings video

Preface

Congratulations

In choosing a VDO computer, you have opted for high-quality device with first rate technology.

To optimally use the computer, we recommend that you read this manual carefully. It contains full operating instructions and many useful tips.

We hope you enjoy cycling with your VDO computer.

Cycle Parts GmbH

Pack contents

First, please ensure that the contents of this pack are complete:

- 1 VDO computer
- 1 battery for the computer
- 1 speed transmitter, battery installed
- 1 handlebar bracket
- 1 spoke magnet (clip magnet)
Cable ties for attaching the bracket and
the transmitter
- 1 Quick-start instruction manual

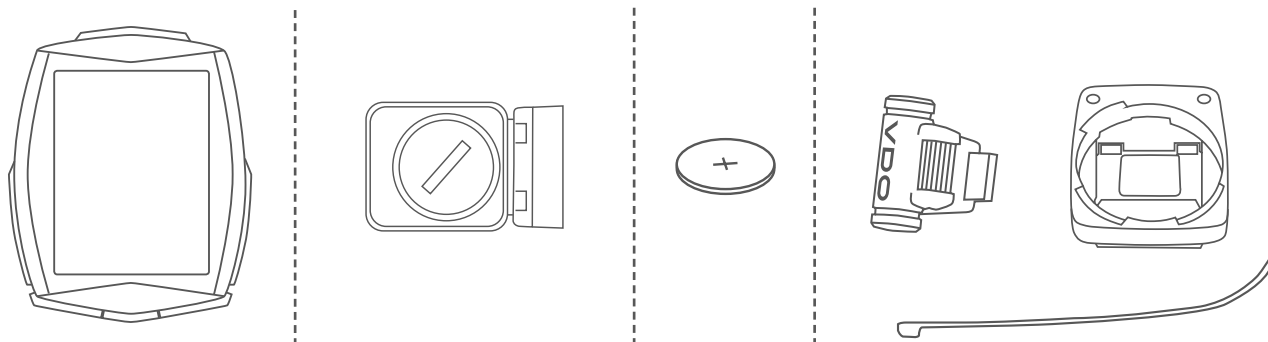

Table of contents

| | | | |
|--|-----------|---|-----------|
| Display | 04 | Setting the navigator | 64 |
| Buttons | 07 | Resetting the navigator to zero | 65 |
| Functions | 08 | Trip section counter | 66 |
| Accessing the total values | 13 | Resetting the trip section counter to zero | 67 |
| Operation while cycling | 17 | Resetting trip data after the trip | 67 |
| Sleep mode | 17 | Saving trip data | 68 |
| Attaching the handlebar bracket | 18 | Accessing the trip data from the memory | 69 |
| Attaching the speed transmitter | 19 | Bike selection: bike 1 or bike 2 | 69 |
| Inserting the computer into the bracket | 20 | Light mode | 70 |
| Pairing the transmitter (initial use) | 21 | Heart rate option | 71 |
| Function testing | 21 | Activating the heart rate option | 71 |
| Settings | 22 | Display when using the heart rate option | 72 |
| Language | 22 | Button allocation with the heart rate option | 72 |
| Dimension | 24 | Functions in the heart rate option | 73 |
| Wheel circumference | 26 | Selecting heart rate zones | 75 |
| My data | 30 | Cadence option | 76 |
| Sensor selection | 32 | Activating the cadence option | 76 |
| Heart rate intensity zones | 33 | Display when using the cadence option | 77 |
| Start altitudes | 36 | Button allocation and functions | |
| Current altitude | 37 | with the cadence function | 78 |
| Recalibrating the altitude before starting | 39 | Attaching the cadence transmitter | 78 |
| Clock | 40 | Heart rate and cadence options | |
| Date | 42 | simultaneously activated | 78 |
| Beeper | 44 | Display with heart rate and cadence | 79 |
| Total values | 45 | Functions with heart rate and cadence options | 80 |
| Total distance | 46 | Replacing the battery in the computer | 81 |
| Total ride time | 48 | Replacing the battery in the speed transmitter | 82 |
| Altitude gain | 50 | Terms of guarantee | 83 |
| Altitude loss | 52 | Troubleshooting | 84 |
| Maximum altitude | 54 | Technical specifications | 85 |
| Distance uphill | 56 | | |
| Distance downhill | 58 | | |
| Total calorie burn | 60 | | |
| Resetting the total values | 62 | | |

Display

The VDO M6 has a large, easy-to-read display that can be divided into six areas.

Area 1:

The altitude is permanently displayed on the left of the top line of the display.

Area 2:

The temperature is permanently displayed on the right.

If the heart rate function is selected: the gradient uphill/downhill is displayed.

If the cadence option is selected: the cadence is displayed.

If the heart rate + cadence option is selected: the cadence is displayed.

Area 3:

The current speed is permanently displayed on the right in the middle line of the display.

Area 4:

The gradient uphill/downhill is displayed on the left as a percentage.

If the heart rate function is selected: the current heart rate is displayed.

Area 5:

A description of the selected indicator function is displayed in this area in clear text.

Area 6:

The value for the selected function is displayed in the bottom line.

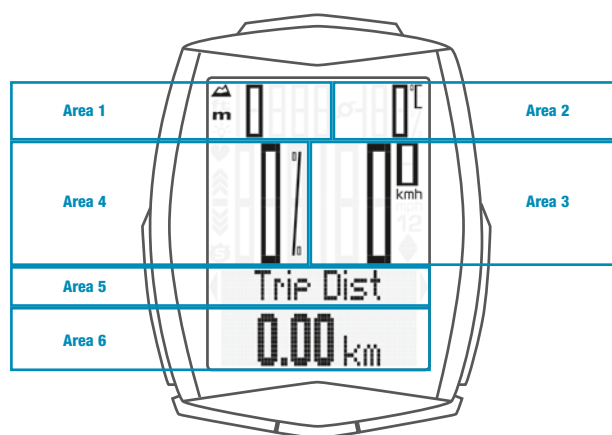

Display with heart rate option



Display with cadence option

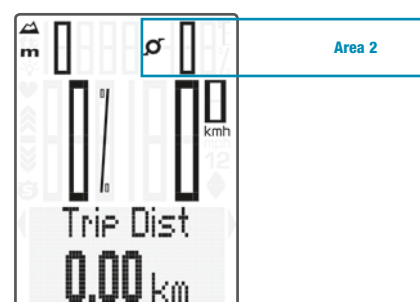

Display with heart rate + cadence option

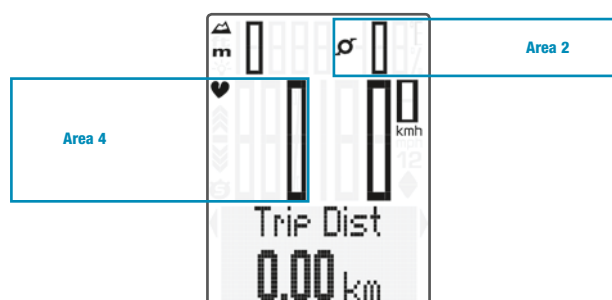

Display



On the right of the display, under the speed indicator, the unit kmh or mph is displayed. The active bike is also shown in this area.

“1 2”

The VDO M6 can be used on two bikes. The indicator icons 1 and 2 show you whether your VDO M6 is currently using the settings for bike 1 or bike 2.

A description of how to switch between bike 1 and bike 2 can be found on page 69.



“UP/DOWN arrow” ▲ ▼

The arrows indicate whether you are currently travelling quicker or slower than your current average speed.

Display

The following icons are shown on the left of the display next to the gradient uphill percentage:

“**S**”: the icon is ON if the trip section counter has been started. A more detailed description of the trip section counter can be found on page 65.

Light mode ON/OFF : This icon indicates whether the display backlight mode is switched on or off.

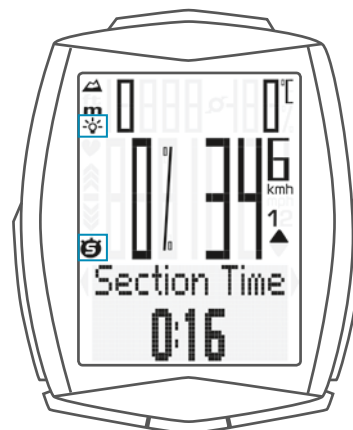

Left/right arrows next to the description of the selected indicator function (area 5 of the display).

In setting mode, these arrows indicate that you can scroll by pressing the BIKE or the TPC (TOTAL/PULSE/CAD) button or increase/reduce the value with both buttons.

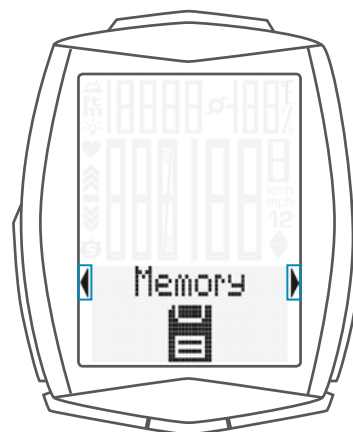

Buttons

The VDO M6 has four buttons.

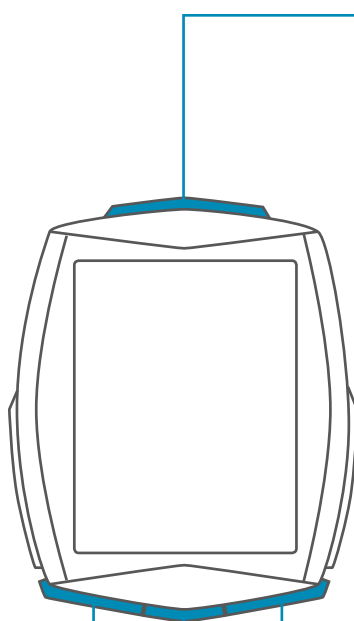

SET

In function mode:

- Scroll backwards through the functions
- Open the setting mode (press and hold)
- Access the total values for distance and ride time (press and hold)
- Access the stored trip data (press and hold)

In setting mode:

- Open the setting
- Confirm the setting once ready
- Exit setting mode and return to function mode

TPC (TOTAL/PULSE/CAD)

In function mode:

- Access the totals for distance/ride time
- Access the heart rate functions if the heart rate option is activated
- Access the cadence functions if the cadence option is activated

In setting mode:

- Scroll in the setting menu (backwards)
- Change the data to be set (decrease)

BIKE

In function mode:

- Access the functions (scroll forwards through the functions)
- Reset trip data to zero (press and hold)

In setting mode:

- Scroll in the setting menu (forwards)
- Change the data to be set (increase)

ALTI

In function mode:

- Access the altitude data for the current trip
- Access the altitude recalibration (press and hold)

In setting mode:

- Exit setting mode/one level back/back to function mode

Functions

The VDO M6 has the following functions:

Current speed

The current speed is permanently shown on the display. For a wheel circumference of 2,155 mm, the maximum possible speed is 199 kmh or 124 mph.



Current altitude

The current altitude is permanently displayed on the top left.



Current temperature

The current temperature is permanently displayed on the top right.

ATTENTION: if the **HEART RATE option** is activated, the current gradient uphill/downhill is displayed here.

ATTENTION: if the **CADENCE option** is activated, the current cadence is displayed here. See page 76.



With
HEART RATE option

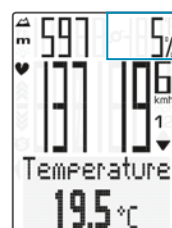

With
CADENCE option

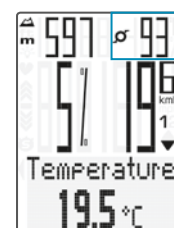

Current gradient uphill/downhill

The current gradient uphill/downhill is displayed as a percentage on the left of the middle line.



Functions

Current gradient uphill/downhill

ATTENTION: if the **HEART RATE option** is activated, the current heart rate is displayed here. The gradient uphill now appears at the top right.

ATTENTION: if the **heart rate + cadence option** is activated, the gradient uphill is displayed as part of the altitude information (access by pressing the ALTI button).

With
HEART RATE option

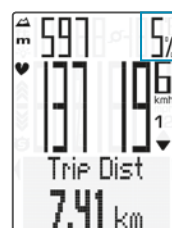

With HEART RATE +
CADENCE option



Press the **BIKE button** to access the following information:

Current distance

The current distance counts up to 9,999.99 km or miles. If this value is exceeded, the current distance count restarts at zero.



Current ride time

The current ride time counts up to 99:59 HH:MM. If this value is exceeded, the ride time count restarts at zero.



Average speed

for the current trip

The average speed is specified to two decimal places.



Maximum speed

for the current trip

The maximum speed is specified to two decimal places.



Functions

Section time

The VDO M6 has a trip section counter.

The trip section counter is like a stopwatch.

If the trip section counter is running, the section time is recorded, as with a stopwatch. When the trip section counter is running, the section distance is also recorded.

The trip section counter is started and stopped by pressing the **BIKE + SET** buttons (simultaneously press and BRIEFLY hold both buttons).

ATTENTION: the trip section counter stops automatically when the speed is ZERO.



Section distance

Shows the distance travelled while the trip section counter is activated.



Navigator

The navigator is a second, completely independent trip distance counter.

The navigator is used to measure trip sections.

The navigator is particularly helpful when riding a route shown in a road book (e.g. Moser Bike Guide).

The navigator can:

- be reset to ZERO as often as desired and independently of the trip distance counter
- be preset to a specific value
- count forwards or backwards from this value

Information on how to operate the navigator can be found on page 64.



Functions

Time

The current time is displayed in 24 H or 12 H mode.

Information on how to set the time can be found on page 40.



ALTI button functions

Press the **ALTI button** to access the altitude information for the current trip:

Elevation profile for the current trip

The elevation profile for a section of the current trip is displayed.



Altitude gain

The altitude gain for the current trip is displayed here.



Maximum altitude

The maximum altitude achieved so far on the current trip is displayed here.



Average gradient uphill

Displays the average gradient uphill for the current trip.



ALTI button functions

Maximum gradient uphill

Displays the maximum gradient uphill so far on the current trip.



Uphill distance

Displays the uphill distance travelled on the current trip.



Altitude loss

Displays the altitude loss on the current trip.



Average gradient downhill

Displays the average gradient downhill for the current trip.



Maximum gradient downhill

Displays the maximum gradient downhill so far on the current trip.



ALTI button functions

Downhill distance

Displays the downhill distance travelled on the current trip.



Accessing the total values

The total values for the distance travelled, the ride time and the altitude data are accessed separately to the data for the CURRENT trip.

There are **two options** for displaying the totals.

OPTION 1:

Access the totals by pressing the TPC (TOTAL/PULSE/CAD) button.

ATTENTION: if you have activated the **HEART RATE option**, the total values can be accessed via the menu.

This is described under **option 2**.

Total distance 1

(total for all trips on bike 1)

The total distance counts up to 99,999 km or miles. If this value is exceeded, the total distance counter restarts at zero.

If the unit is switched from miles to km and the conversion result is greater than 100,000 km, the value is reset to ZERO.

Now press the **TPC (TOTAL/PULSE/CAD) button** to scroll to the **total ride time**

(total for all trips)

The total ride time counts up to 9999:59 HHHH:MM. If this value is exceeded, the total ride time count restarts at zero.



Accessing the total values

Maximum altitude of all trips with bike 1

Displays the maximum altitude you have reached on all trips with bike 1.



Altitude gain – totals

Displays the total altitude gain for all trips with bike 1.



Uphill distance – totals

Displays the total uphill distance you have ridden on bike 1.



Altitude loss – totals

Displays the total altitude loss with bike 1.



Downhill distance – totals

Shows the total downhill distance you have ridden on all trips with bike 1.



Accessing the total values

If you have also used bike 2, the values for bike 2 are also displayed here.

Press the **TPC (TOTAL/PULSE/ CAD) button** to scroll to the other values for bike 2.

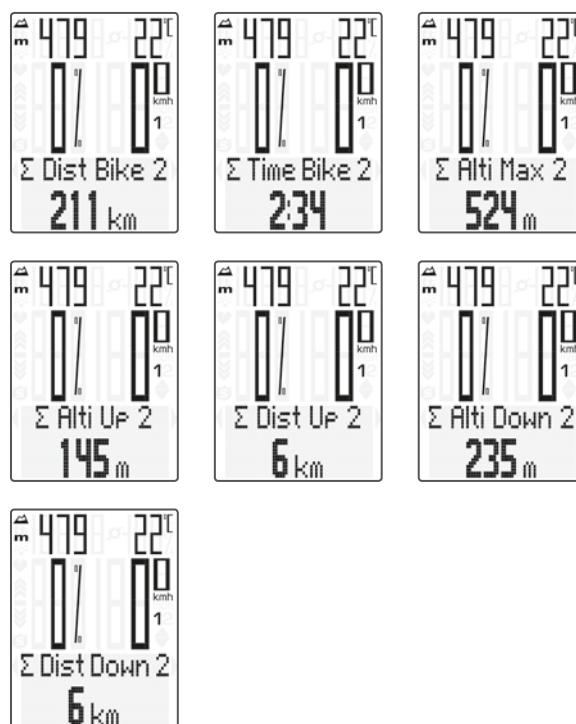

You can also access the **total values** (sum of the data for bike 1 and bike 2).

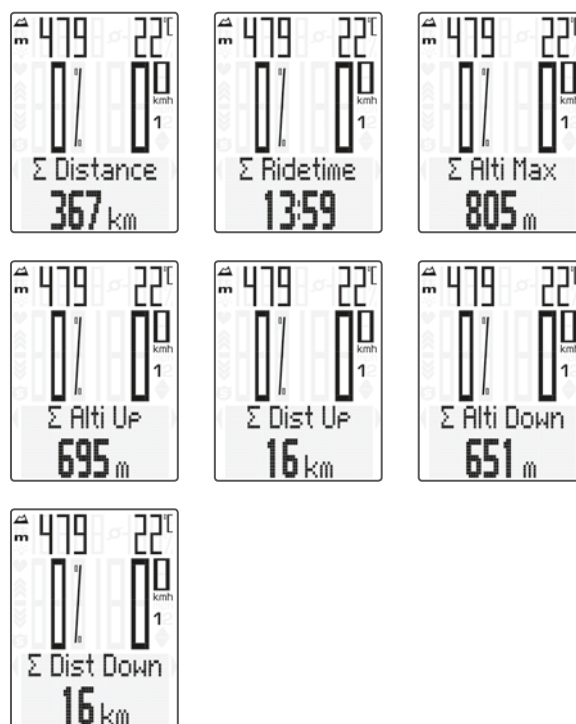

Accessing the total values

OPTION 2:

Press and hold the SET button until the menu opens.

- Press the **BIKE** or **TPC button** to scroll to the total values.
- Press the **SET button** to open the total values display.
- Press the **BIKE** or **TPC button** to scroll in the total values.

The total distance 1 (sum of all individual trips with bike 1) is displayed first.

- Press the **BIKE** or **TPC button** to scroll to the other totals.

If you have also used **bike 2**, the values for bike 2 are also displayed here.

You can also access the total values for bike 1 + bike 2 here: If the **HEART RATE option** is activated, you will also receive totals data for your **calorie burn**:

- **Calorie burn with bike 1**
- **Calorie burn with bike 2**
- **Total calorie burn with bike 1 + bike 2**

Press (and hold) the SET button to return from the total values information to the normal function mode.

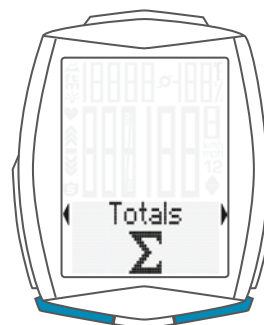

Operation while cycling

While cycling, the display functions can be accessed by pressing the **BIKE** button and the **ALTI** button (**scroll forwards** through the functions).

Pressing the BIKE or ALTI button shows the next function on the display.

If the **HEART RATE option** is activated, the heart rate functions are displayed by pressing the TPC button.

By pressing the **SET button** you can also **scroll backwards through the functions**. This enables you to quickly display the desired function.

The totals can be accessed by pressing the TPC (total/pulse/CAD) button.

ATTENTION: if the HEART RATE option is activated, the heart rate functions are displayed by pressing the TPC button.

A more detailed description can be found on page 06.



Sleep mode

If you take a break and the **M6 is in the bracket**, the computer switches to **standby mode** after **five minutes**.

If you set off again after a break, the VDO M6 has an **auto-start function**.

The auto-start function is activated by a movement sensor.

Moving the handlebars is enough to wake up the M6 from sleep mode. The VDO M6 immediately switches to function mode. The current speed and the distance are once again displayed after a few seconds.

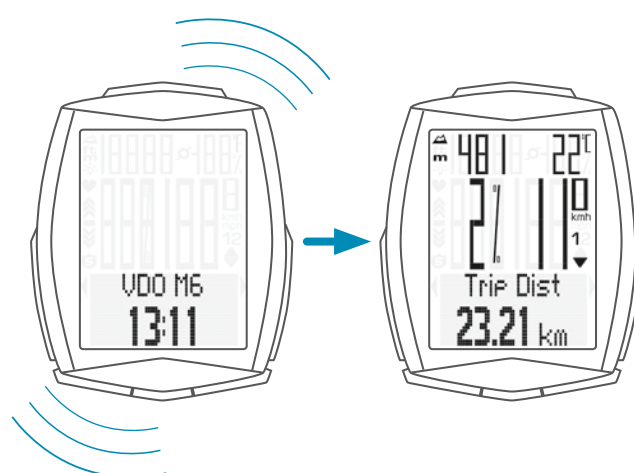

Attaching the handlebar bracket

You can attach the computer to the right or left of the handlebars or in the centre on the stem. Attach the handlebar bracket in the corresponding position.

STEP 1

Decide whether you want to attach the computer to the handlebars or the stem.

STEP 2

Rotate the foot of the handlebar bracket by 90° accordingly. To do so, undo the screws in the bracket, remove the foot and rotate it 90° then insert and tighten the screws again.

Attention: do not overtighten the screws.

STEP 3

Guide the cable ties through the slot in the handlebar bracket, place around the handlebars or the stem and pull (do not pull tight just yet).

STEP 4

For handlebar attachment: align the computer angle to achieve optimum readability. Now pull the cable ties tight.

Use clippers to snip off protruding ends.

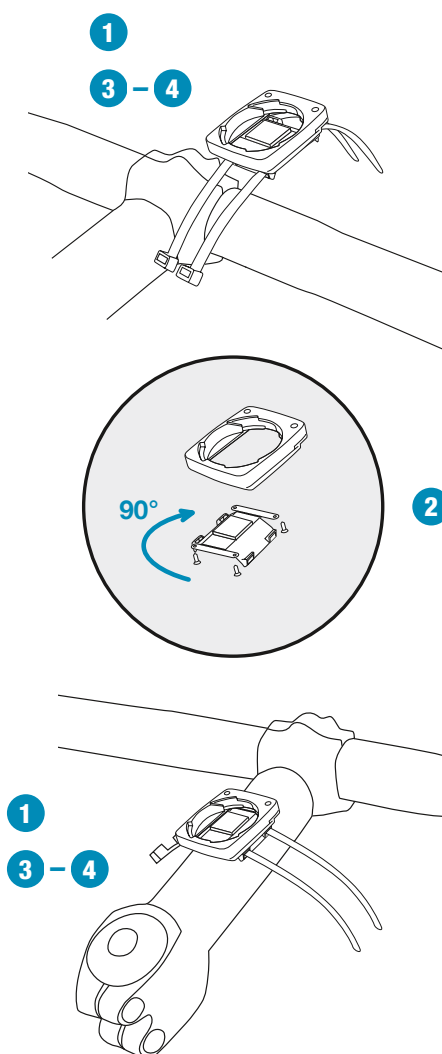

Attaching the speed transmitter

The transmitter can be attached to the fork leg on the right or left.

Note:

If you have attached the computer to the stem or the left of the handlebars, the speed transmitter MUST be attached to the LEFT fork leg.

STEP 1

Place the rubber shim under the transmitter. Fit the transmitter on the same side of the forks where you later want to fit the computer to the handlebars (right or left) using the cable ties supplied (loosely at first, do not pull tight just yet).

ATTENTION: The cross-hatched marking on the lid of the transmitter's battery compartment must point toward the spokes.

Depending on the available space, the transmitter can be mounted along the front of the fork, on the inside of the fork, or the back of the fork.

STEP 2

Place the spoke magnet around an outside spoke. The VDO logo of the rod-shaped magnet core should point toward the transmitter. Align the magnet with the cross-hatched sensor marking on the transmitter at a distance of 1-5 mm.

STEP 3

Align the transmitter and magnet in their final positions and fasten them in place:
pull the cable ties tight and push the magnet in firmly.
The transmitter should be folded down at a maximum angle of 45° to the spokes. If you cannot achieve this angle, move the transmitter down along the fork leg towards the hub until you have reduced the angle to less than 45° .

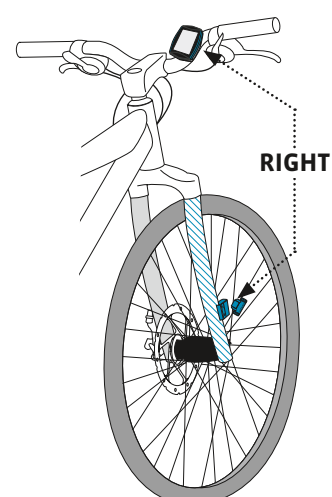
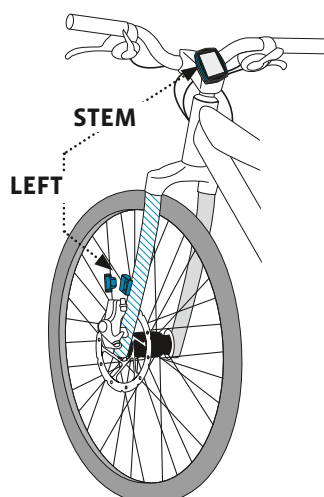
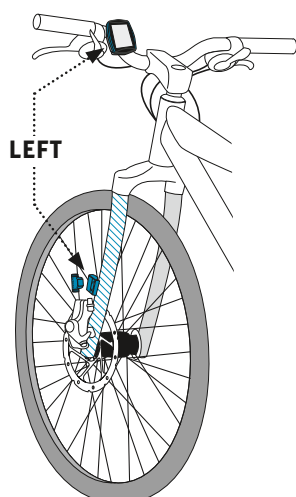
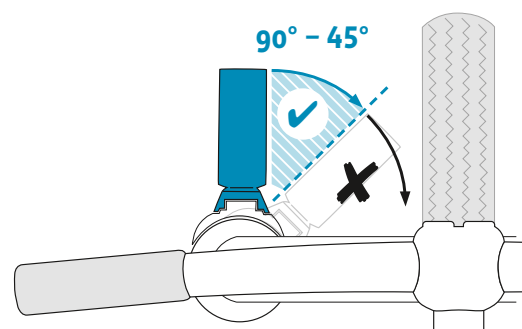
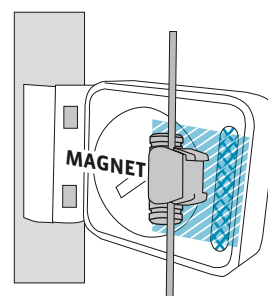
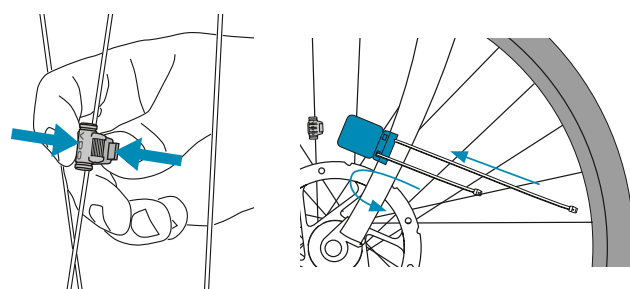

Inserting the computer into the handlebar bracket

The VDO twist-click system securely connects the computer to the handlebar bracket.

How to insert the computer:

STEP 1

Place the computer into the bracket in a 10 o'clock position.

STEP 2

Rotate the computer to the right into the 12 o'clock position and click it into the bracket system. A noticeable resistance must be overcome to move it into place.

STEP 3

To remove the computer, rotate it to the left (without pushing or pulling).

Memory aid: **R**igid to the **R**ight, **L**oose to the **L**eft

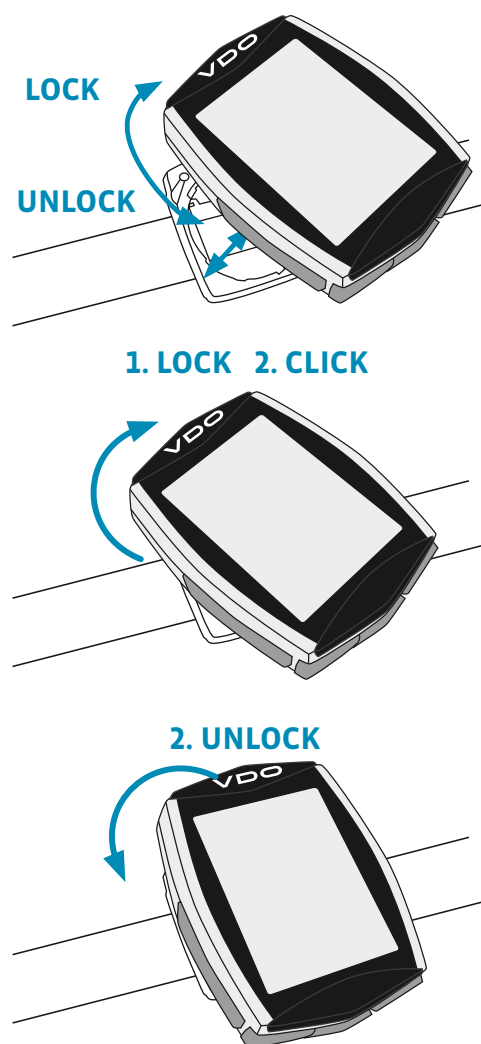

Pairing the transmitter (initial use)

The VDO M6 automatically pairs the transmitter.

Once the computer has been rotated into place in the bracket, it starts searching for the transmitter.

The transmitter search is identified by the flashing digits for:

- Speed
- Heart rate (if the heart rate option is activated)
- Cadence (if the cadence option is activated)

The VDO M6 has an automatic bike recognition function. Depending on whether you are using bike 1 or bike 2, the data is recorded for bike 1 or bike 2.

ATTENTION: When other radio signals interfere during the pairing function, the display shows the message **“Too Many Signals”**.

Confirm this message by pressing any key. You will then need to leave this location and move to another location. Untwist the computer from the handlebar bracket. Then reinsert the computer into the handlebar bracket. The computer will now attempt another pairing.

Potential source of interference:

- LED lights
 - Mobile telephone
 - GPS receiver
 - WLAN
 - Anti-theft security systems inside the store
- These sources can interfere with the pairing.

ATTENTION: when using the transmitter for the first time, the bike recognition switch must be set to either BIKE 1 or BIKE 2. Only then will the automatic bike recognition work.

Press and **HOLD** the button until the LED flashes.

Green flashes once = bike 1 is selected

Red flashes twice = bike 2 is selected

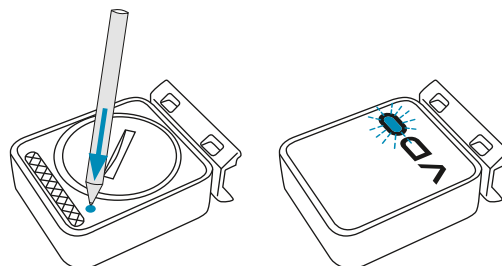

Function testing

Once the transmitter is attached, check that it functions correctly.

How to test the transmitter:

- Insert the computer into the bracket.
 - The speed indicator flashes. The computer now searches for its speed transmitter.
- Lift and spin the front wheel.
 - The green LED on the transmitter flashes several times.
- A speed should now be displayed on the computer.

If the cadence option is activated, the cadence transmitter must also be paired:

- The cadence indicator flashes. The computer now searches for its cadence transmitter.
- Rotate the crank or set off.
 - The green LED on the cadence transmitter flashes several times.
- A speed should now be displayed on the computer.

If the heart rate option is activated, the heart rate transmitter must also be paired:

- The heart rate indicator flashes. The computer now searches for its heart rate transmitter.
- Put on the heart rate transmitter and wait a few seconds.
- A heart rate should now be displayed on the computer.
 - If no speed, cadence or heart rate is displayed, there can be several reasons for this.

The possible reasons are described in the **“Troubleshooting”** section.

Settings – language

The following display languages can be selected for the VDO M6:

- German
- English
- French
- Italian
- Spanish
- Dutch

How to select the language:

Press and hold the SET button until the settings menu opens.

The first thing to appear is **MEMORY**.

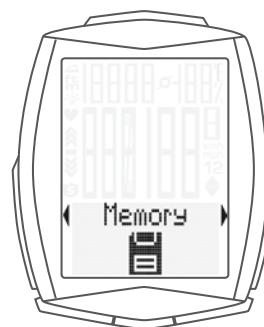

Press the **Bike button** to scroll to **Settings**.



Press the **SET button** to open the settings. **“Language”** appears on the display.



Press **SET** to open the **language** settings. English flashes.

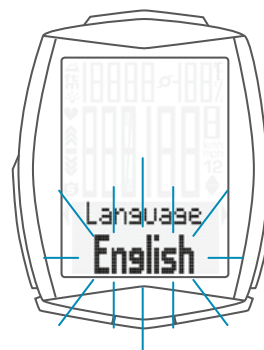

Settings – language

You can now press the **BIKE button** to select a different language.



Press the **SET button** to confirm your language setting.
The response **“Set OK”** appears on the display.

If you want to configure further settings, press the **BIKE button** to access these.

If you do not want to configure any further settings,
press and hold the SET button.

The settings menu closes.
The VDO M6 returns to function mode.



Settings – Dimension

Use the unit settings to specify the measurement formats for:

- Speed (kmh or mph)
- Altitude (metres or feet)
- Temperature (C or F)
- Weight (kg or lbs)
- Time (24-hour or 12-hour with AM/PM)
- Date (DD-MM-YY or MM-DD-YY)

How to select the units:

Press and hold the SET button until the settings menu opens.

From **Memory** press the **BIKE button** to scroll to **Settings**.

Press the **SET button** to open the settings.

“**Language**” appears on the display.

Press the **BIKE button** to scroll to the setting for the **Dimension**.

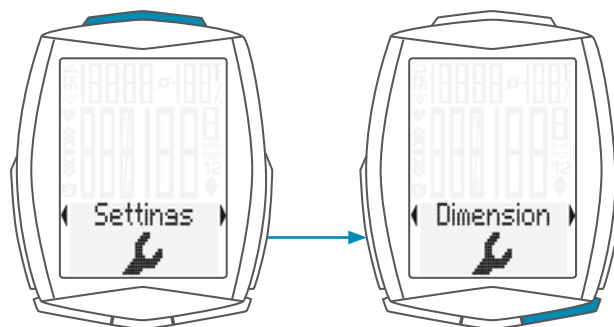

Press the **SET button** to open the unit setting.
First set the unit for the **speed**.

“**KMH**” flashes in the bottom line of the display.
Press the **BIKE button** to change the unit to “**MPH**”.

Press the **SET button** to confirm the setting.

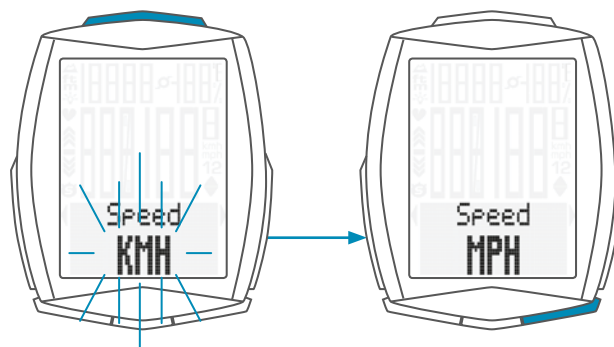

The setting for the **altitude** unit next appears in metres or feet.

Press the **BIKE button** to switch from **metres** to **feet**.

Press the **SET button** to confirm the setting.

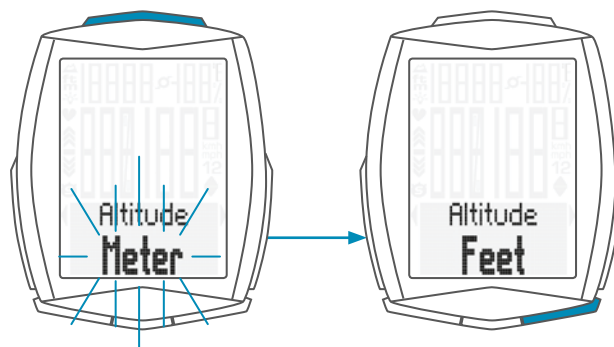

The setting for the **temperature** unit next appears on the display. Set whether the temperature should be displayed in **Celsius** or **Fahrenheit**.

Press the **BIKE button** to make your selection.

Press the **SET button** to confirm your selection.

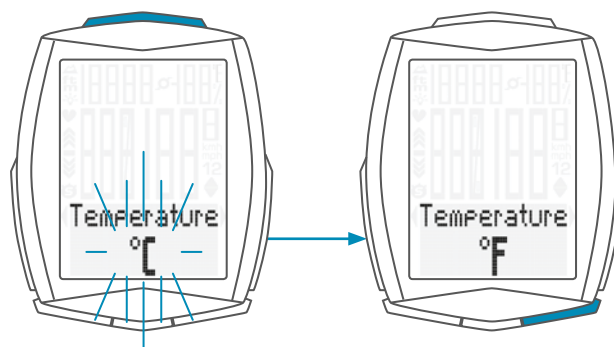

Settings – Dimension

The setting for the unit **weight** now appears on the display. **KG** or **LBS (POUNDS)** can be selected.

Press the **BIKE button** to make the selection.

Press the **SET button** to confirm the selection.

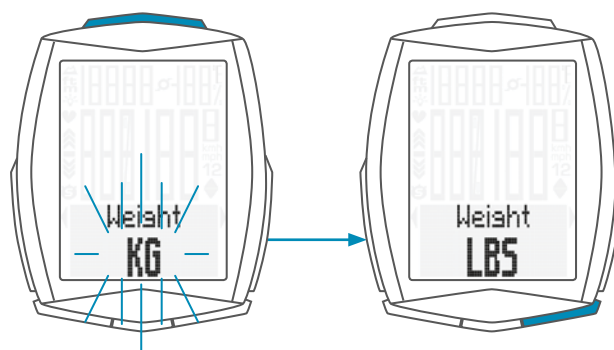

The setting for the **time format** now appears on the display. Here, you can select a **24-hour** format or a **12-hour** format with AM/PM.

Press the **BIKE button** to make the selection.

Press the **SET button** to confirm the selection.

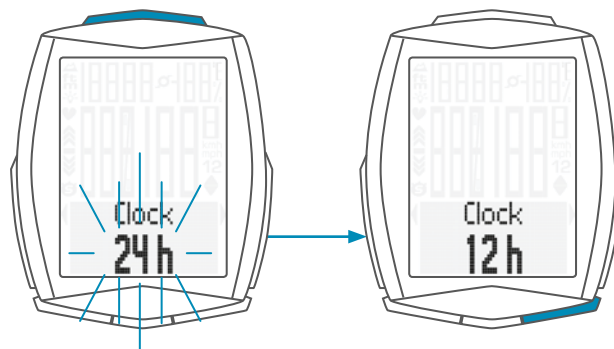

The setting for the **date format** now appears on the display. You can choose between the European format and the English format.

Press the **BIKE button** to make the selection.

Press the **SET button** to confirm the selection.

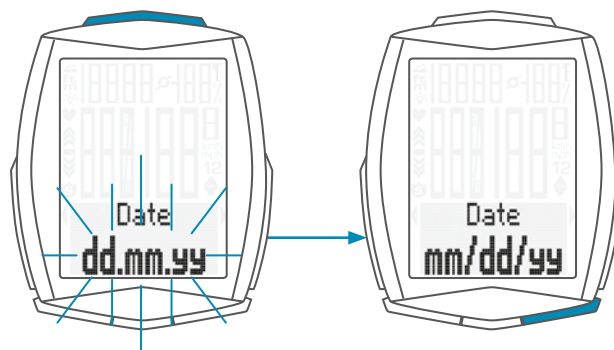

The response **“Dimension Set OK”** appears on the display.

If you want to configure further settings, press the **BIKE** or **TPC button** to access these.

If you do not want to configure any further settings, **press and hold the SET button**.
The settings menu closes.

The VDO M6 returns to function mode.



Settings – wheel circumference/wheel size

You can set the roll circumference of your wheel in millimetres on the VDO M6 or select the applicable tyres from a tyres table.

The more accurate this setting, the more accurate your speed indicator and the measurement of the distance you have travelled. You can find the values for your tyres in the tyre size table and set these in the device.

ATTENTION: the values in the table are approximations only. The actual values can deviate from the values in the table depending on the manufacturer and the tyre tread.

If your tyre size is not listed in the table, you can accurately measure the roll circumference.

How to measure the roll circumference:

STEP 1

Stand your bike up and position the wheel to which you want to attach the sensor so that the valve is directly on the ground. Ensure that the tyres are fully pumped up in accordance with the usage instructions. Mark the position of the valve on the ground with a line or adhesive strip.

STEP 2

Now push your bike forwards in a straight line until the valve is back on the ground after one rotation. Again mark the position of the valve on the ground with a line or adhesive strip.

STEP 3

The distance between the two marks corresponds to your wheel circumference or wheel size in millimetres.

| Tyre size | ETRTO | KMH Wheel circumference in mm | MPH Wheel circumference in inches |
|-----------|--------|--|--|
| 16 x 1.75 | 47-305 | 1,272 | 50.1 |
| 20 x 1.75 | 47-406 | 1,590 | 62.6 |
| 24 x 1.75 | 47-507 | 1,907 | 75.1 |
| 26 x 1.5 | 40-559 | 2,026 | 79.8 |
| 26 x 1.75 | 47-559 | 2,070 | 81.5 |
| 26 x 1.9 | | 2,089 | 82.2 |
| 26 x 2.00 | 50-559 | 2,114 | 83.2 |
| 26 x 2.10 | 54-559 | 2,125 | 83.6 |
| 26 x 2.25 | 57-559 | 2,145 | 84.4 |
| 26 x 2.35 | 60-559 | 2,160 | 85.0 |
| 26 x 2.40 | 62-559 | 2,170 | 85.4 |
| 28 x 1.5 | 40-622 | 2,224 | 87.6 |
| 28 x 1.6 | 42-622 | 2,235 | 88.0 |
| 28 x 1.75 | 47-622 | 2,268 | 89.3 |
| 29 x 2.10 | 54-622 | 2,295 | 90.3 |
| 29 x 2.25 | 57-622 | 2,288 | 90.1 |
| 29 x 2.40 | 62-622 | 2,300 | 90.5 |
| 650 B | | 2,100 | 82.6 |
| 700 x 18C | 18-622 | 2,102 | 82.8 |
| 700 x 20C | 20-622 | 2,114 | 83.2 |
| 700 x 23C | 23-622 | 2,095 | 82.5 |
| 700 x 25C | 25-622 | 2,146 | 84.5 |
| 700 x 30C | 30-622 | 2,149 | 84.6 |
| 700 x 32C | 32-622 | 2,174 | 85.6 |
| 700 x 38C | 38-622 | 2,224 | 87.6 |

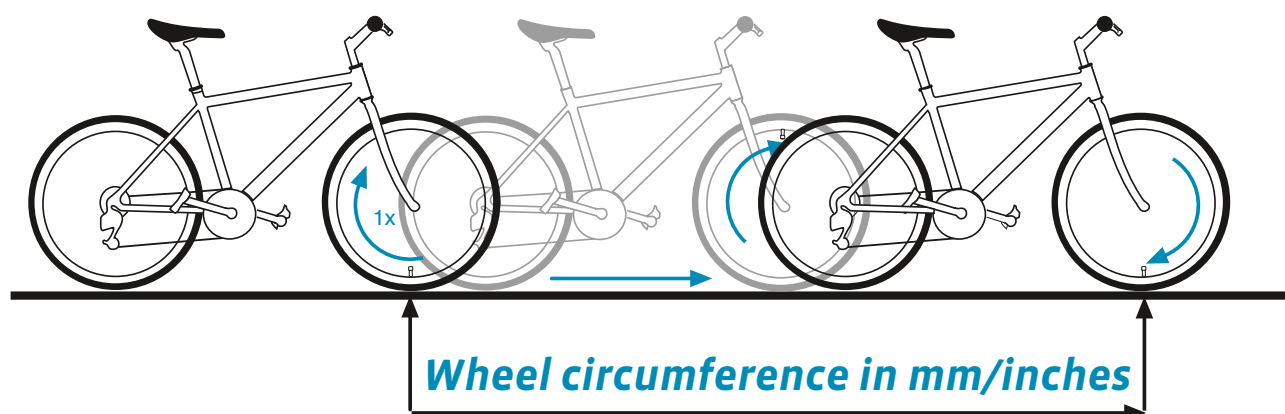

Settings – wheel circumference/wheel size

How to set your wheel circumference:

Press and hold the **SET** button until the settings menu opens.

Press the **BIKE** button to move from Memory to Settings.
Press the **SET** button to open the settings.

“Language” appears on the display.

Press the **BIKE** or **TPC** button to scroll to the setting for the **wheel size**.

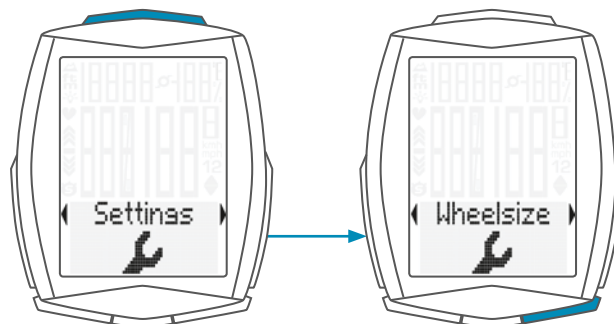
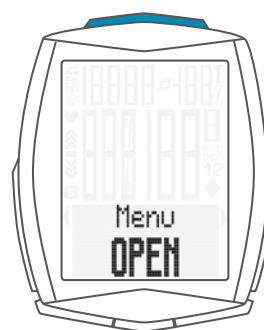

Press the **SET** button to open the setting for the **wheel size**.

You can set the wheel size separately for bike 1 and bike 2.
Press the **BIKE** button to scroll from the setting for bike 1 to the setting for bike 2.

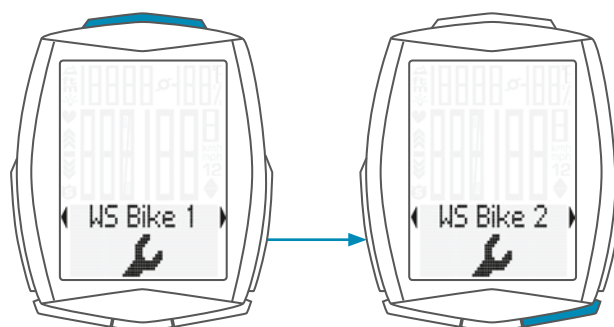

Press the **SET** button to open the setting (description here is for bike 1).

In the display, you can now choose whether you want **to manually set the wheel size in millimetres or select the appropriate tyres from a tyre list**.

Press the **BIKE** button to make the selection.
Confirm the selection by pressing the **SET** button.

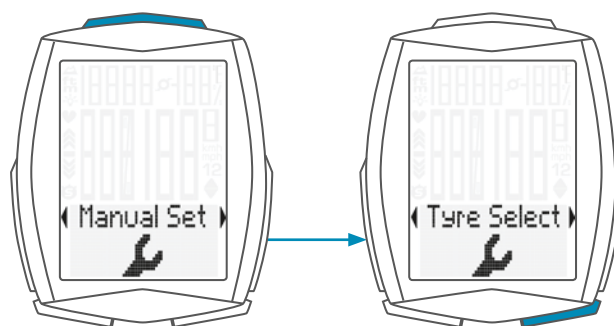

Settings – wheel circumference/wheel size

Manual setting by entering the roll circumference in millimetres

The first two digits (in the example “21”) flash.
Press the **BIKE** or **TPC button** to set these digits to the desired value.

Press the **SET button** to confirm your setting.



The third digit now flashes and is ready to be set.
Press the **BIKE** or **TPC button** to set these digits.

Press the **SET button** to confirm your setting.

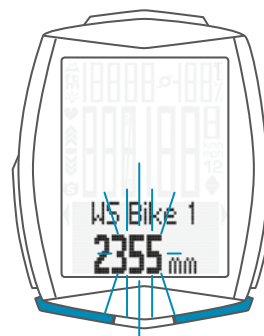

The final digit on the right now flashes.
Press the **BIKE** or **TPC button** to set these digits.

Press the **SET button** to confirm your setting.
Your wheel circumference is now fully set.
The response “**Set OK**” appears on the display.

If you want to configure further settings, press the **BIKE** or **TPC button** to access these.

If you do not want to configure any further settings,
press and hold the SET button.
The settings menu closes.

The VDO M6 returns to function mode.

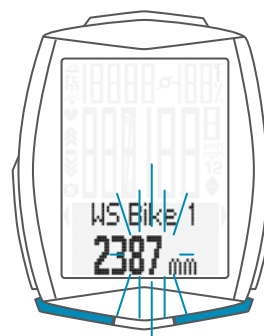

Settings – wheel circumference/wheel size

Setting the wheel size using the tyre list

Open the wheel size settings via the tyres list by pressing the **SET button** (see previous page).



Press the **BIKE** or **TPC button** to scroll through the tyre list until your tyres are displayed (in the example shown 29 x 2.40)



Press the **SET button** to confirm the selection. The response "**Set OK**" appears on the display.

If you want to configure further settings, press the **BIKE** or **TPC button** to access these.

If you do not want to configure any further settings, **press and hold the SET button**. The settings menu closes.

The VDO M6 returns to function mode.



Settings – my data

Use the **My data** settings to set your data for your age, weight, gender, HR max for the heart rate measurement and lower/upper limits for the heart rate training zone.

How to set your My data information:

Press and hold the **SET button** until the settings menu opens.

Press the **BIKE button** to move from Memory to Settings.

Press the **SET button** to open the settings.
“Language” appears on the display.

Press the **BIKE button** to scroll to the settings for **My Data**.

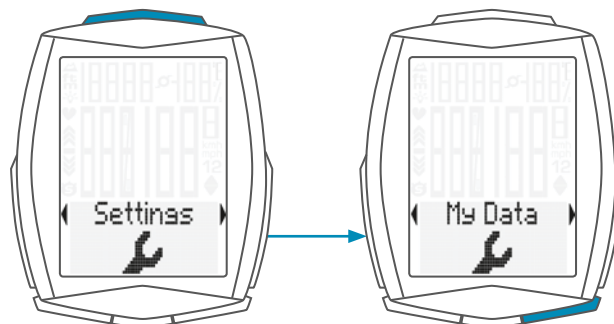
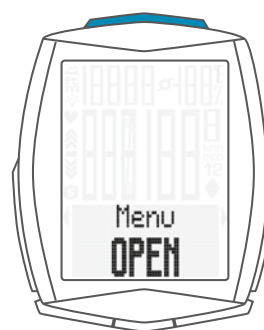

Press the **SET button** to open the setting.
 First, set your age.

Press the **BIKE button** to **increase** the value and the
TPC button to **decrease** the value.

Press the **SET button** to confirm the value you have set.



Now set your weight.

Press the **BIKE button** to **increase** the value and the
TPC button to **decrease** the value.

Press the **SET button** to confirm the value you have set.



Now set your gender.

Press the **BIKE button** or the **TPC button** to select
 your gender.

Press the **SET button** to confirm the value you have set.

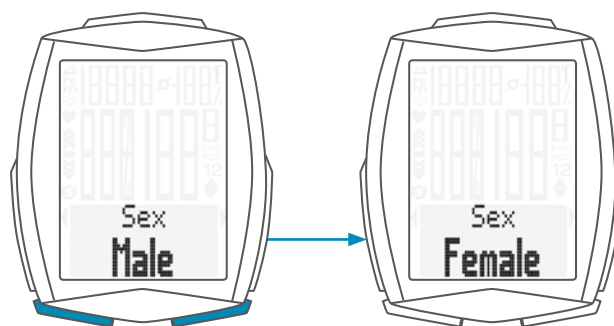

Settings – my data

The **HR max** calculated on the basis of your data is now displayed.

HR max is the maximum heart rate value that you should not exceed while training.

If you know your HR max, you can set the value here. If you do not know the value, you should work with the calculated value.

Press the **BIKE button to increase** the value and the **TPC button to decrease** the value.

Press the **SET button** to confirm the value you have set.



After entering your HR max, you can now define the lower and upper limits for the heart rate training zone.

Press the **BIKE button to increase** the value and the **TPC button to decrease** the value.

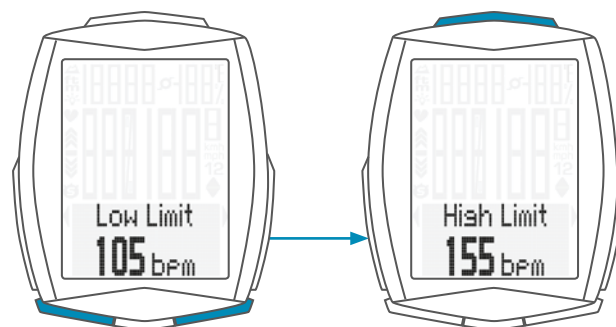

Press the **SET button** to confirm the value you have set. The response "**Set OK**" appears on the display.

If you want to configure further settings, press the **BIKE** or **TPC button** to access these.

If you do not want to configure any further settings, **press and hold the SET button**.

The settings menu closes.

The VDO M6 returns to function mode.



Settings – sensor selection

The M6 can display heart rate and (simultaneously) cadence data.

To do this, a heart rate and/or cadence transmitter must be available and installed. Use the sensor selection menu to select the sensor that should be activated.

ATTENTION: once a transmitter has been selected, the sensor values (heart rate/cadence) appear on the display. The display changes.

The layout of the functions on the buttons also changes.

Further information on this is provided on page 71 for the

heart rate option and on page 76 for the **cadence option**.

How to select the sensors:

Press and hold the **SET button** until the settings menu opens.

Press the **BIKE button** to move from **Memory to Settings**.

Press the **SET button** to open the setting.

“**Language**” appears on the display.

Press the **BIKE button** to scroll to the setting for the sensors.

Press the **SET button** to open the settings.

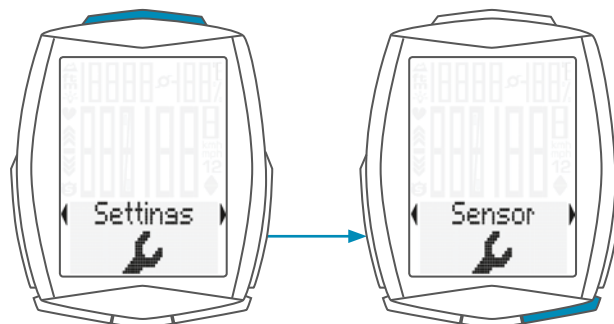
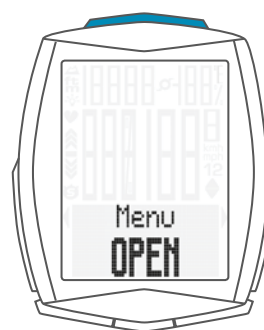

Heart rate OFF or ON flashes.

Press the **BIKE or TPC button** to select **ON** or **OFF**.

Press the **SET button** to confirm the selection.

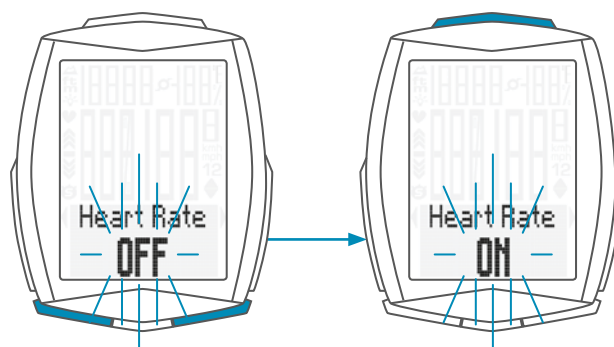

You can now select whether the **cadence transmitter** should be activated.

Press the **BIKE or TPC button** to select **ON** or **OFF**.

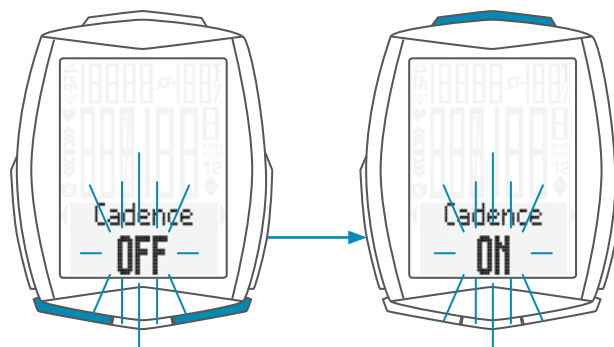

Settings – sensor selection

Press the **SET button** to confirm the selection.
The response **“Set OK”** appears on the display.

If you want to configure further settings,
press the **BIKE** or **TPC button** to access these.

If you do not want to configure any further settings,
press and hold the **SET button**.
The settings menu closes.

The VDO M6 returns to function mode.



Settings – heart rate intensity zones

On the M6, you can set four heart rate intensity zones for heart rate measurement.

When training using your heart rate (heart rate transmitter), a record is made of how long you spent in the intensity zones 1 to 4.

These values enable you to analyse your training in detail.

How to set the heart rate intensity zones:

Press and hold the SET button until the settings menu opens.

Press the **BIKE button** to move from **Memory to Settings**.

Press the **SET button** to open the settings.
“Language” appears on the display.

Press the **BIKE button** to scroll to the setting for the **HR intensity zones**.

Press the **SET button** to open the settings.

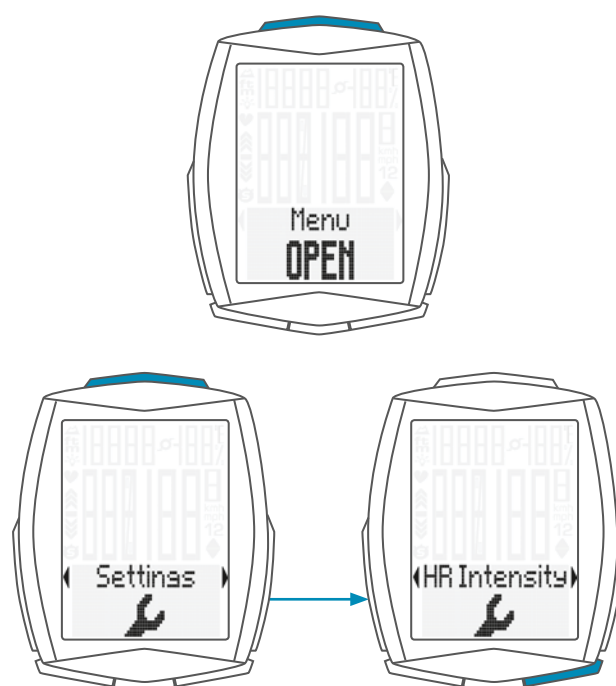

Settings – heart rate intensity zones

Now press the **BIKE** or **TPC button** to select the setting for **intensity zones 1 to 4**.

Press the **SET button** to confirm the selection.



The setting for the selected intensity zone is opened.
The **value** to be set (lower zone limit) **flashes on the left**.

Press the **BIKE button** to **increase** the value and the **TPC button** to **decrease** the value.

Press the **SET button** to confirm your setting.

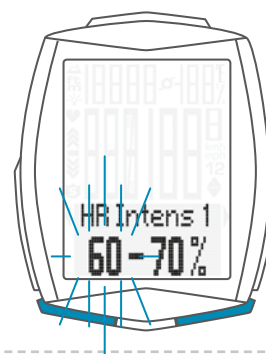

The **right-hand value** (upper zone limit) now **flashes**.

Press the **BIKE button** to **increase** the value or the **TPC button** to **decrease** the value.

Press the **SET button** to confirm your setting.

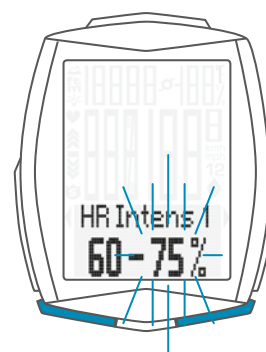

Settings – heart rate intensity zones

You can now adjust the **next intensity zone** (e.g. zone 2).
The intensity zones are predefined.
You can individually adapt each of the intensity zones
to your training requirements.

Press the **BIKE button to increase** the value and the
TPC button to decrease the value.

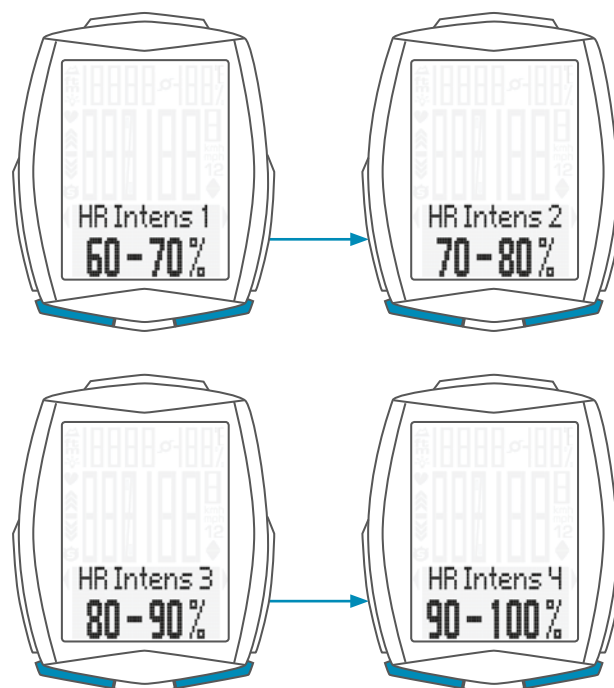

Press the **SET button** to confirm your setting.
The response **“Set OK”** appears on the display.

If you want to configure further settings,
press the **BIKE** or **TPC button** to access these.

If you do not want to configure any further settings,
press and hold the SET button.
The settings menu closes.

The VDO M6 returns to function mode.



Settings – start altitude

You can enter two different start altitudes on the M6. Start altitude 1 can be your home start altitude, for example. Start altitude 2 can be the start altitude at a holiday location.

After entering the start altitude, the current altitude measured can be quickly and easily recalibrated as the start altitude before any trip.

The key word here is ‘recalibrated’:

Recalibration must occur before every trip.

The M6 measures the current air pressure and converts it into an altitude measurement. However, the air pressure changes daily depending on the weather. This leads to a constantly changing **current altitude measurement** despite your start altitude not having changed.

During recalibration, the currently measured air pressure is calculated back to the set start altitude. Following recalibration, the current altitude once again matches the set start altitude. You can now set off.

How to set the start altitudes:

Press and hold the SET button until the settings menu opens.

Press the **BIKE button** to switch from **Memory to Settings**. Press the **SET button** to open the settings.

“**Language**” appears on the display.

Press the **BIKE button** to scroll to the setting for the start altitude.

Press the **SET button** to open the setting for the **home altitude**.

Press the **BIKE** or **TPC button** to select **Home altitude 1** or **Home altitude 2**.

Press the **SET button** to open the settings.

Press the **BIKE button** to **increase** the value for the start altitude.

Press the **TPC button** to **decrease** the value for the start altitude.

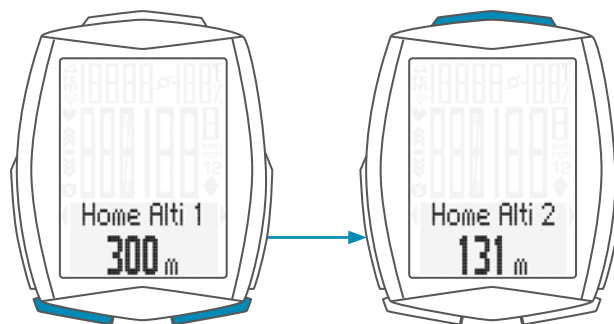
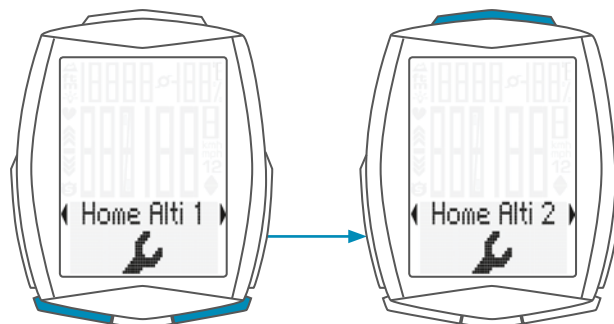
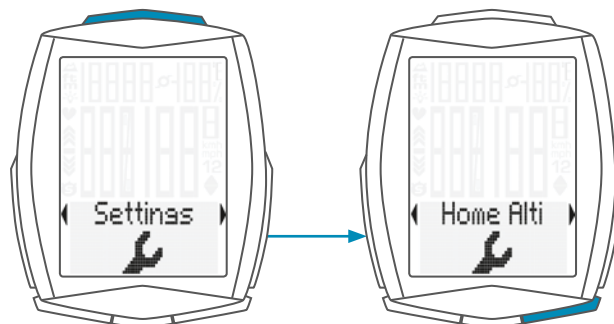
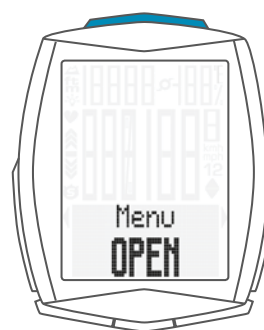

Settings – start altitude

Once the correct start altitude has been set, confirm the setting by pressing the **SET button**. The response “**Set OK**” appears on the display.

If you want to configure further settings, press the **BIKE** or **TPC button** to access these.

If you do not want to configure any further settings, **press and hold the SET button**. The settings menu closes.

The VDO M6 returns to function mode.



Settings – current altitude

The current altitude can be set on the M6.

The current altitude is set, for example, if you are not starting from either of the two set start altitudes or you encounter altitude information on a pass that differs from the current altitude displayed on your M6.

The current altitude can be specified in metres/feet or as sea level pressure. The sea level pressure information can be obtained from several weather websites.

How to set the current altitude:

Press and hold the SET button until the settings menu opens.

Press the **BIKE button** to move from **Memory to Settings**.

Press the **SET button** to open the settings.

“**Language**” appears on the display.

Press the **BIKE** or **TPC button** to scroll to the setting for the **Actual altitude**.

Press the **SET button** to open the setting for the **Actual altitude**.

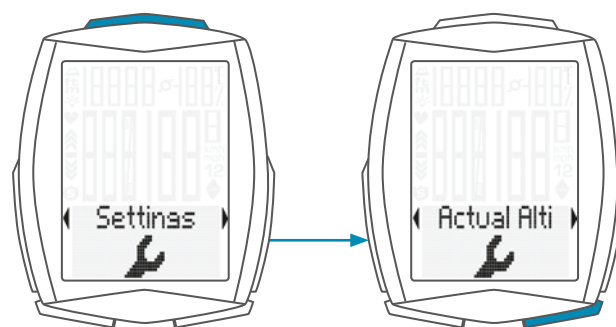
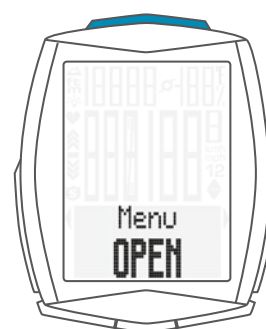

Settings – current altitude

Press the **BIKE** or **TPC button** to select whether you want to set the altitude in **metres/feet** or **sea level pressure**.

Press the **SET button** to confirm the selection.

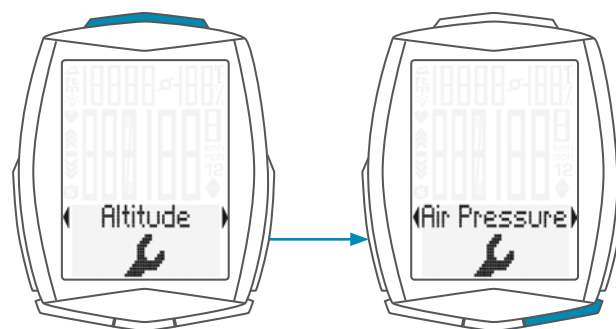

The settings now open.

Press the **BIKE** or **TPC button** to change the value.

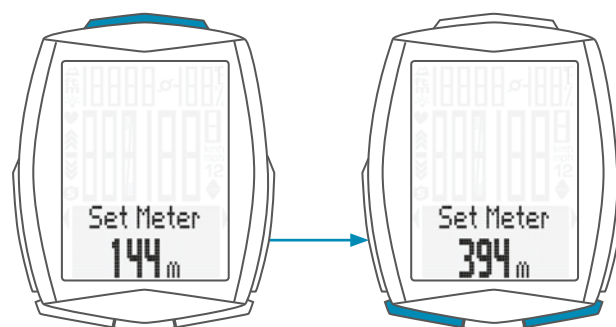

Setting by means of the sea level pressure.

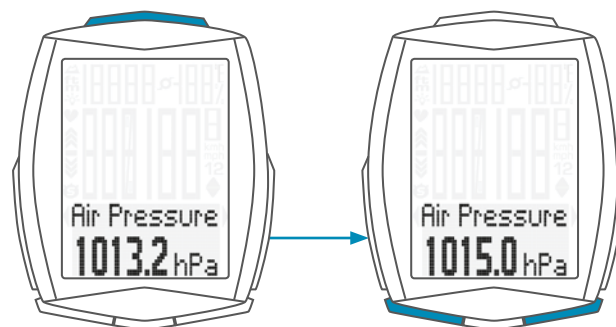

Press the **SET button** to confirm the setting.
The response **“Set OK”** appears on the display.

If you want to configure further settings,
press the **BIKE** or **TPC button** to access these.

If you do not want to configure any further settings,
press and hold the SET button.

The settings menu closes.

The VDO M6 returns to function mode.



Settings – recalibrating the altitude before starting

Recalibration means:

The M6 measures the current air pressure and converts it into an altitude measurement.

The air pressure changes daily depending on the weather. This leads to a constantly changing current altitude measurement despite your home start altitude not having changed.

During recalibration, the currently measured air pressure is calculated back to the set home start altitude.

Following recalibration, the M6 again correctly displays the home start altitude as the current altitude.

You must now recalibrate before starting a trip.

How to recalibrate:

Press and hold the ALTI button until the menu opens.

Press **BIKE** or **TPC** to scroll to **HOME ALTITUDE 1** or **HOME ALTITUDE 2** depending on where you are setting off from.

Now press **SET** to confirm the desired start altitude.

The start altitude is saved and displayed as the **CURRENT ALTITUDE**.

You can now set off.

In addition to choosing between the two start altitudes, you can also manually set the **CURRENT ALTITUDE**.

Do this if you are not setting off from either **HOME ALTITUDE 1** or **HOME ALTITUDE 2**.

The **CURRENT ALTITUDE** is set in metres. If you do not know the altitude, you can alternatively use the “**sea level pressure**” entry. The relevant air pressure data can be found on several weather websites.

The computer can now use this information to calculate and display the current altitude.

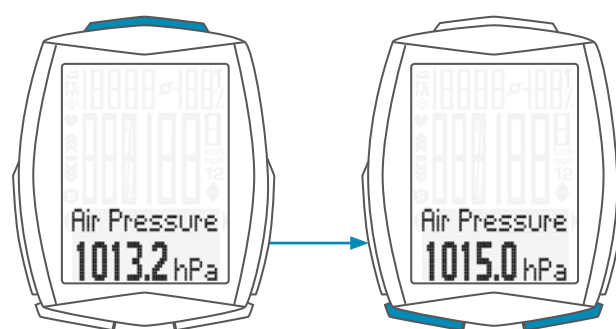
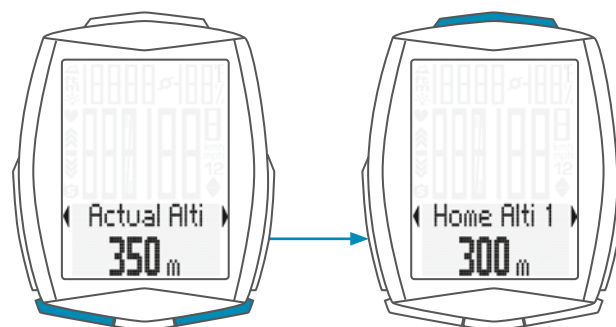

Settings – clock

In the VDO M6, you can set the time in 12-hour AM/PM format or 24-hour format.

Specify the desired time format in the unit settings (see page 24).

How to set the clock:

Press and hold the SET button until the settings menu opens.

Press the **BIKE button** to move from **Memory to Settings**.

Press the **SET button** to open the settings.

“**Language**” appears on the display.

Press the **BIKE** or **TPC button** to scroll to the setting for the **Clock**.

Press the **SET button** to open the setting for the **Clock**.

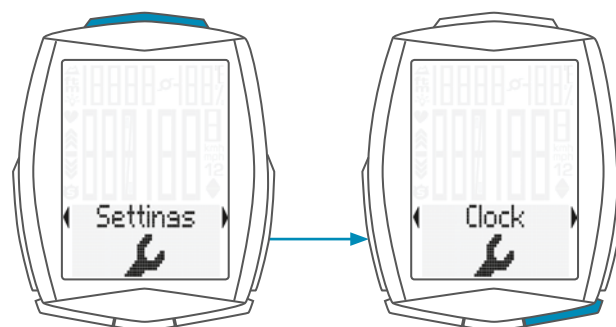

The hour digits flash.

Press the **BIKE** or **TPC button** to change the setting for the **hours**.

Press the **SET button** to confirm your setting.

Display in 24-h format

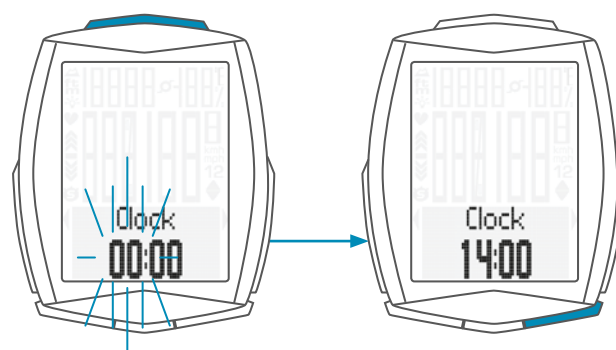

Display in 12-h format

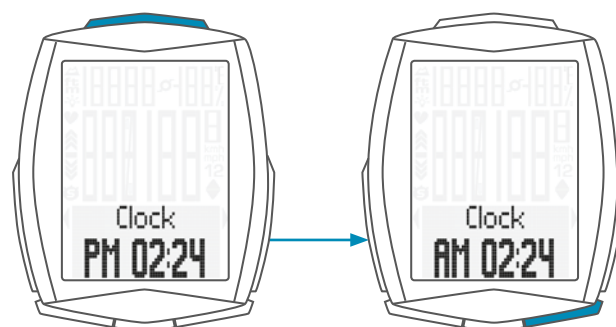

Settings – clock

The minute digits now flash on the display.
Press the **BIKE** or **TPC button** to set the **minutes**.

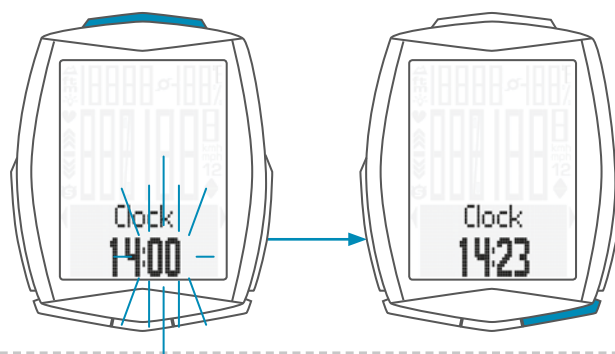

Press the **SET button** to confirm your setting.
The response **“Set OK”** appears on the display.

If you want to configure further settings,
press the **BIKE** or **TPC button** to access these.

If you do not want to configure any further settings,
press and hold the SET button.
The settings menu closes.

The VDO M6 returns to function mode.



Settings – date

You can set the date on the M6.
The date can be set in the format DD/MM/YY or MM/DD/YY. Specify the date format in the dimension settings.
See page 24.

How to set the date:

Press and hold the **SET** button until the settings menu opens.

Press the **BIKE** button to switch from **Memory to Settings**.

Press the **SET** button to open the settings.

“Language” appears on the display.

Press the **BIKE** or **TPC** button to scroll to the settings for the **Date**.

Press the **SET** button to open the settings.

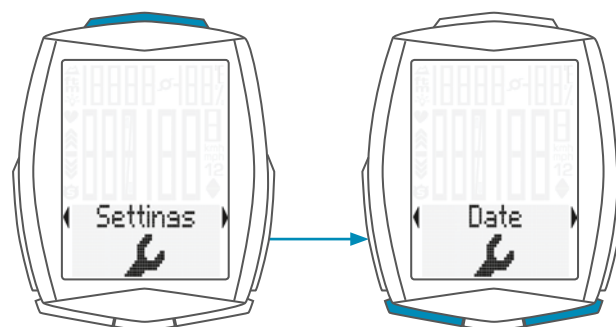
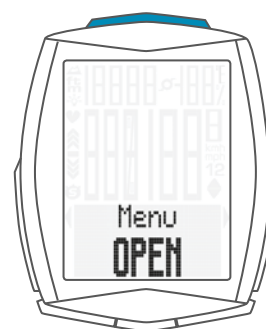

Press the **SET** button to open the settings.

First, the year is set.

Press the **BIKE** or **TPC** button to change the setting.

Press the **SET** button to confirm the setting.

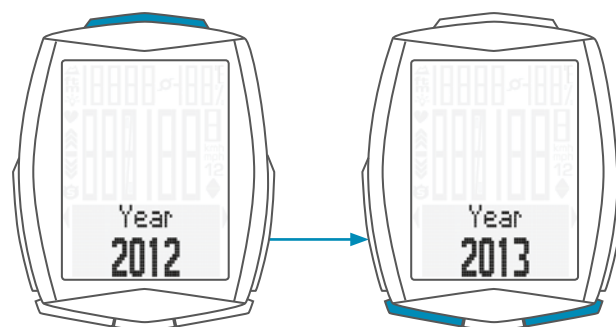

You can now set the month.

Press the **BIKE** or **TPC** button to change the setting.

Press the **SET** button to confirm the setting.



Now set the day.

Press the **BIKE** or **TPC** button to change the settings.



Settings – date

Press the **SET button** to confirm the setting.
The response “**Set OK**” appears on the display.

If you want to configure further settings,
press the **BIKE** or **TPC button** to access these.

If you do not want to configure any further settings,
press and hold the SET button.
The settings menu closes.

The VDO M6 returns to function mode.



Settings – switching the beeper on or off

On the M6, you can switch the beeper for the heart rate warning on or off.

How to set the beeper:

Press and hold the SET button until the settings menu opens.

Press the **BIKE button** to move from **Memory to Settings**.

Press the **SET button** to open the settings.

“**Language**” appears on the display.

Press the **BIKE** or **TPC button** to scroll to the settings for the **Beeper**.

Press the **SET button** to open the settings.

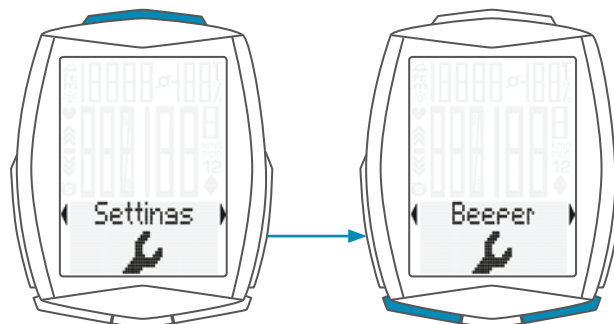
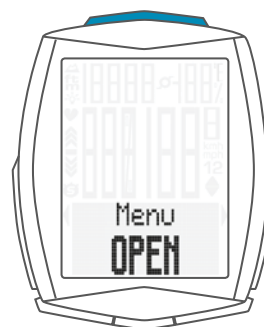

Press the **BIKE** or **TPC button** to select whether the **beeper should be switched on or off**.

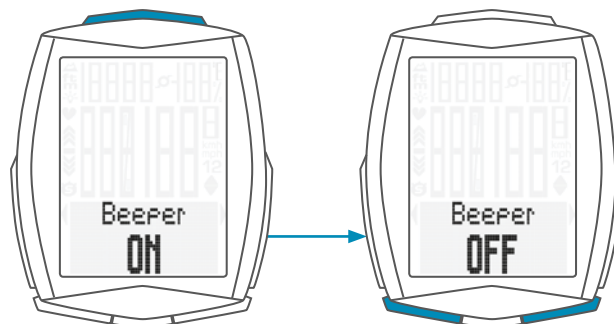

Press the **SET button** to confirm the setting.
The response “**Set OK**” appears on the display.

If you want to configure further settings,
press the **BIKE** or **TPC button** to access these.

If you do not want to configure any further settings,
press and hold the SET button.

The settings menu closes.

The VDO M6 returns to function mode.



Settings – total values

On the M6, the total values can be set at any time, e.g. at the start of a new season.

ATTENTION: the M6 has a memory for the total values. All total values are still stored even after replacing the battery.

The following total values can be set:

- Total distance
- Total ride time
- Altitude gain
- Altitude loss
- Maximum altitude reached
- Distance uphill
- Distance downhill
- Total calorie burn

For each total value, the values can be separately set for bike 1 and bike 2.

How to set the total values:

Press and hold the SET button until the settings menu opens.

Press the **BIKE button** to move from **Memory to Settings**.

Press the **SET button** to open the settings.

“**Language**” appears on the display.

Press the **BIKE** or **TPC button** to scroll to the settings for the **Total Values**.

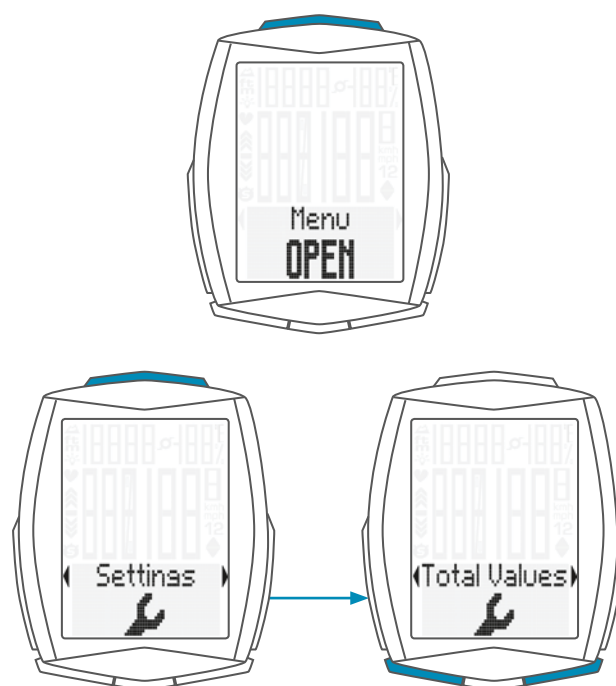

Press the **SET button** to open the setting for the total values.

Press the **BIKE** or **TPC button** to scroll in the total values settings to the desired settings.



Settings – total values – total distance

You can set the total distance ridden on the VDO M6. For example, you can enter your data here at the start of a new cycling season. You can set the total distance separately for bike 1 and bike 2.

ATTENTION: the M6 has a data memory.
No data is lost when the battery is replaced.

How to set the total distance:

Press and hold the **SET** button until the settings menu opens.

Press the **BIKE** button to move from **Memory** to **Settings**.

Press the **SET** button to open the settings.

“**Language**” appears on the display.

Press the **BIKE** or **TPC** button to scroll to the settings for the **total values**.

Press the **SET** button to open the settings.

Press the **BIKE** or **TPC** button to scroll to the settings for the **Total Distance**.

Press the **SET** button to open the settings.

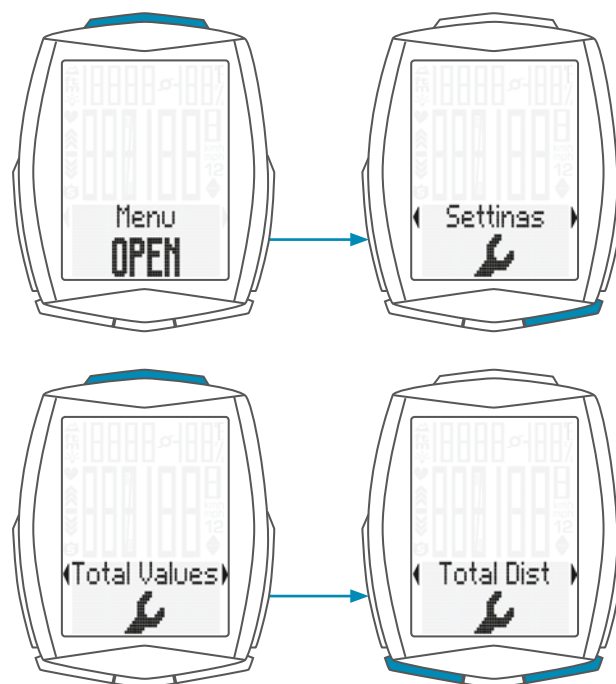

Press the **BIKE** or **TPC** button to select whether you want to set the **total distance** for **bike 1** or **bike 2**.

Press the **SET** button to confirm the selection.

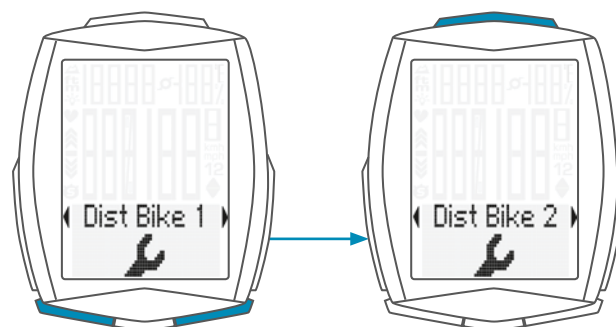

The left digit flashes.

Press the **BIKE** or **TPC** button to change this digit.

Once this digit has been set, confirm the setting by pressing the **SET** button.



Settings – total values – total distance

The **next digit** starts to **flash** and is ready to be set.
Press the **BIKE** or **TPC button** to change this digit.

Once this digit has also been set, confirm the setting
by pressing the **SET button**.

The **next digit flashes**.

Once you have set all the digits, confirm the setting again
by pressing the **SET button**.



The response **“Set OK”** appears on the display.
The set value is stored.

If you want to configure further settings,
press the **BIKE** or **TPC button** to access these.

If you do not want to configure any further settings,
press and hold the **SET button**.
The settings menu closes.

The VDO M6 returns to function mode.



Settings – total values – total ride time

You can set the total ride time on the VDO M6.

For example, you can set your total ride time (sum of the ride time for all trips) at the start of the new cycling season.

You can set the values separately for bike 1 and bike 2.

ATTENTION: the M6 has a data memory.

No data is lost when the battery is replaced.

How to set the total time:

Press and hold the **SET** button until the settings menu opens.

Press the **BIKE** button to move from **Memory** to **Settings**.

Press the **SET** button to open the settings.

“**Language**” appears on the display.

Press the **BIKE** or **TPC** button to scroll to the settings for the **total values**.

Press the **SET** button to open the settings.

Press the **BIKE** or **TPC** button to scroll to the settings for the **Total Time**.

Press the **SET** button to open the setting for the **Total Time**.

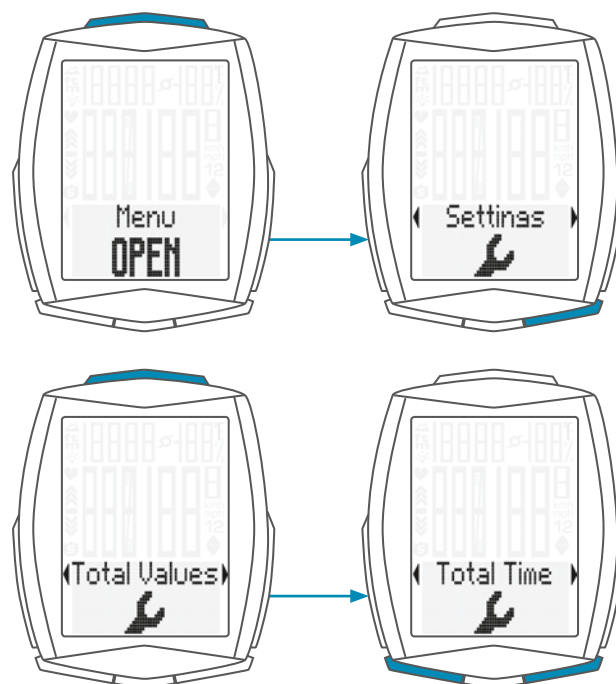

Press the **BIKE** or **TPC** button to select whether you want to set the **total time** for **bike 1** or **bike 2**.

Press the **SET** button to confirm the selection.

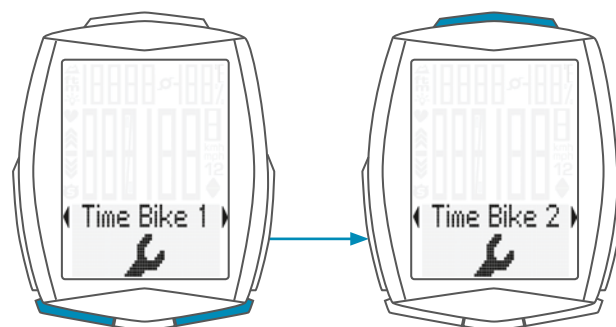

The **left digit** of the **hours setting** **flashes** and is ready to be set.

Press the **BIKE** or **TPC** button to set the value of this digit.

Press the **SET** button to confirm your setting.



Settings – total values – total ride time

The **next digit** on the left starts to **flash** and is ready to be set.
Press the **BIKE** or **TPC button** to set the value of this digit.

Press the **SET button** to confirm your setting.

Once you have set all four digits, confirm the setting again by pressing the **SET button**.

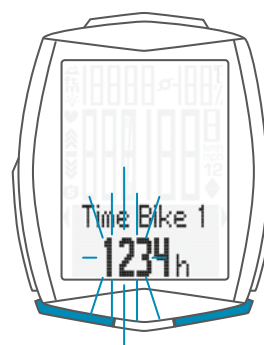

The **setting** for the **minutes** is then opened.
Press the **BIKE** or **TPC button** to set the minutes.

Once the minutes have been set, confirm the setting by pressing the **SET button**.

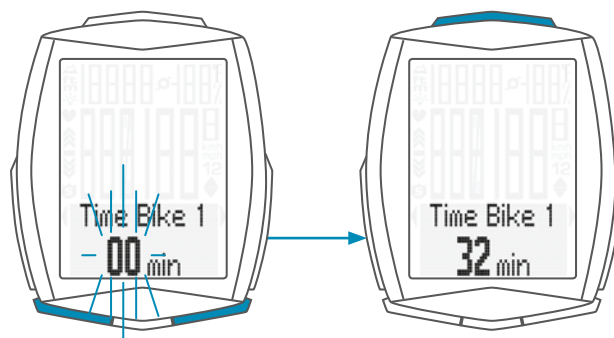

The response **“Set OK”** appears on the display.

If you want to configure further settings, press the **BIKE** or **TPC button** to access these.

If you do not want to configure any further settings, **press and hold the SET button**.
The settings menu closes.

The VDO M6 returns to function mode.



Settings – total values – altitude gain

You can set the altitude gain covered in the M6 at any time. For example, you can set this value at the start of the next cycling season. You can set the values separately for bike 1 and bike 2.

ATTENTION: the M6 has a data memory.
No data is lost when the battery is replaced.

How to set the total altitude gain:

Press and hold the **SET** button until the settings menu opens.

Press the **BIKE** button to move from **Memory** to **Settings**.

Press the **SET** button to open the settings.

“**Language**” appears on the display.

Press the **BIKE** or **TPC** button to scroll to the settings for the **total values**.

Press the **SET** button to open the settings.

Press the **BIKE** or **TPC** button to scroll to the settings for **Alti Up** (altitude gain).

Press the **SET** button to open the settings.

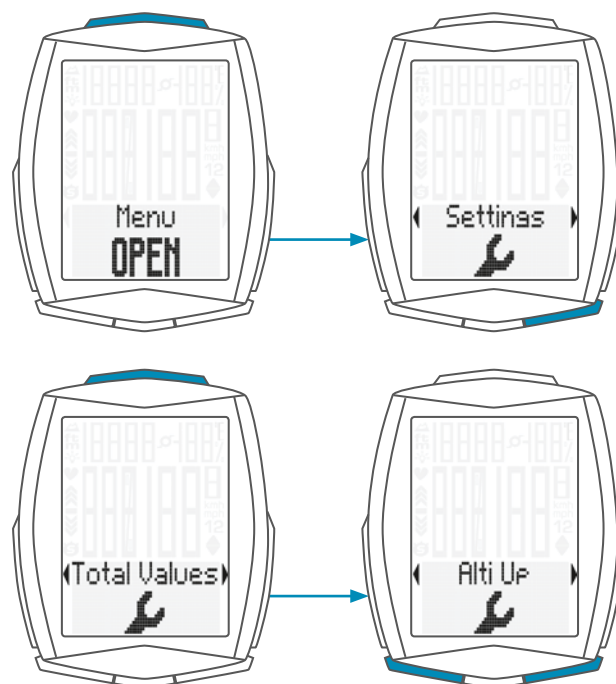

Now press the **BIKE** or **TPC** button to select whether you want to set the **altitude gain** for **bike 1** or **bike 2**.

Press the **SET** button to open the settings.

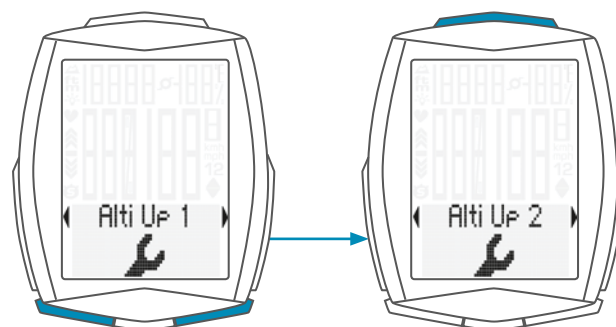

The **left digit** in the settings **flashes** and is ready to be set. Press the **BIKE** or **TPC** button to set the value of this digit.

Press the **SET** button to confirm your setting.

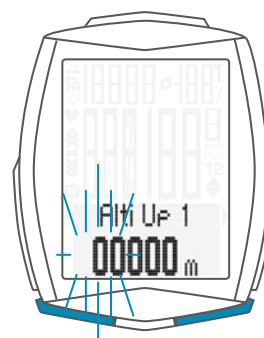

Settings – total values – altitude gain

The **next digit** on the left starts to **flash** and is ready to be set.

Press the **BIKE** or **TPC button** to set the value for this digit.
Press the **SET button** to confirm your setting.

Once all the digits have been set, confirm the setting by pressing the **SET button**.

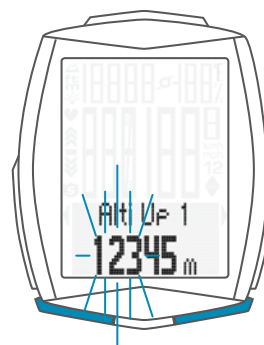

The response **“Set OK”** appears on the display.

If you want to configure further settings, press the **BIKE** or **TPC button** to access these.

If you do not want to configure any further settings, **press and hold the SET button**.
The settings menu closes.

The VDO M6 returns to function mode.



Settings – total values – altitude loss

You can set the altitude loss covered in the M6 at any time. For example, you can set this value at the start of the next cycling season. You can set the values separately for bike 1 and bike 2.

ATTENTION: the M6 has a data memory.
No data is lost when the battery is replaced.

How to set the total altitude loss:

Press and hold the **SET** button until the settings menu opens.

Press the **BIKE** button to move from **Memory** to **Settings**.

Press the **SET** button to open the settings.

“**Language**” appears on the display.

Press the **BIKE** or **TPC** button to scroll to the settings for the **total values**.

Press the **SET** button to open the settings.

Press the **BIKE** or **TPC** button to scroll to the settings for **Alti Down** (altitude loss).

Press the **SET** button to open the settings.

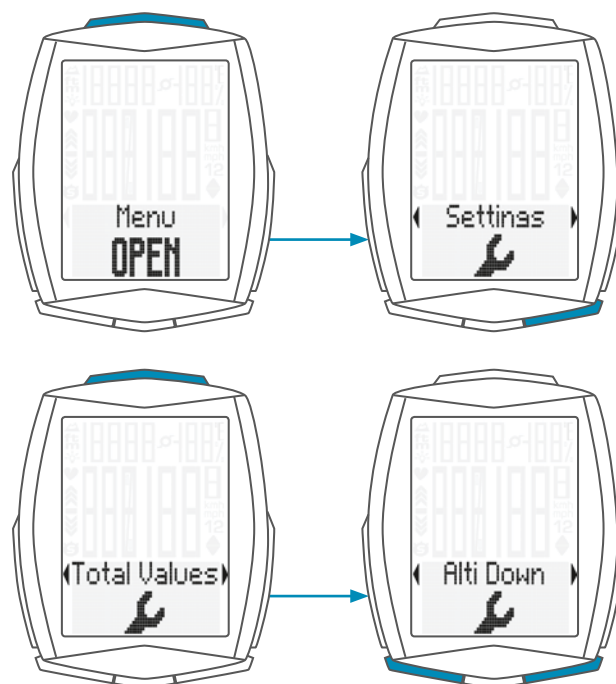

Now press the **BIKE** or **TPC** button to select whether you want to set the **altitude loss** for **bike 1** or **bike 2**.

Press the **SET** button to open the settings.

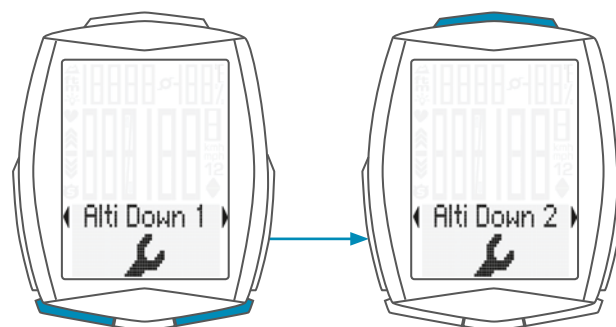

The **left digit** in the settings **flashes** and is ready to be set. Press the **BIKE** or **TPC** button to set the value of this digit.

Press the **SET** button to confirm your setting.



Settings – total values – altitude loss

The **next digit** on the left starts to **flash** and is ready to be set.

Press the **BIKE** or **TPC button** to set the value of this digit.
Press the **SET button** to confirm your setting.

Once all the digits have been set, confirm the setting by pressing the **SET button**.

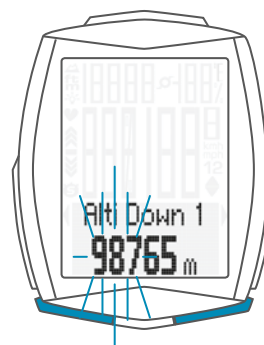

The response **“Set OK”** appears on the display.

If you want to configure further settings, press the **BIKE** or **TPC button** to access these.

If you do not want to configure any further settings, **press and hold the SET button**.
The settings menu closes.

The VDO M6 returns to function mode.



Settings – total values – maximum altitude

You can set the maximum altitude reached to date in the M6, separately for bike 1 and bike 2.

ATTENTION: the M6 has a data memory.
No data is lost when the battery is replaced.

How to set the maximum altitude:

Press and hold the **SET** button until the settings menu opens.

Press the **BIKE** button to move from **Memory** to **Settings**.

Press the **SET** button to open the settings.

“**Language**” appears on the display.

Press the **BIKE** or **TPC** button to scroll to the settings for the **total values**.

Press the **SET** button to open the settings.

Press the **BIKE** or **TPC** button to scroll to the settings for the **Alti Max** (maximum altitude reached).

Press the **SET** button to open the settings.

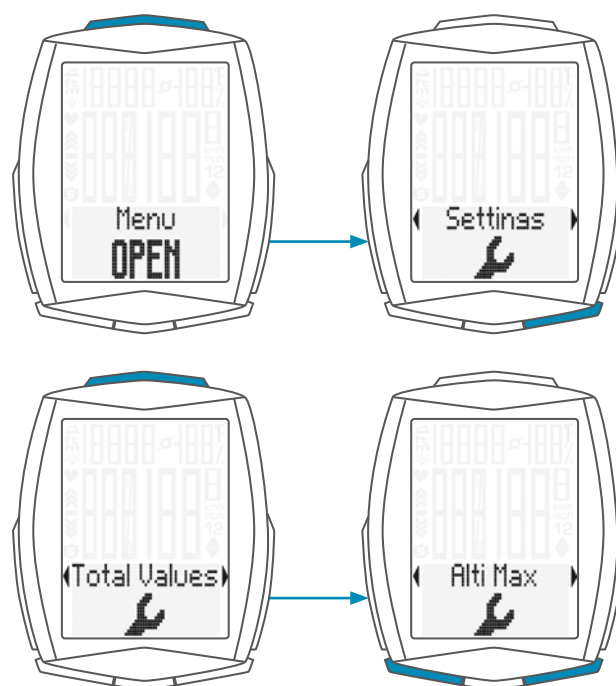

Now press the **BIKE** or **TPC** button to select whether you want to configure the setting for **bike 1** or **bike 2**.

Press the **SET** button to confirm the selection.

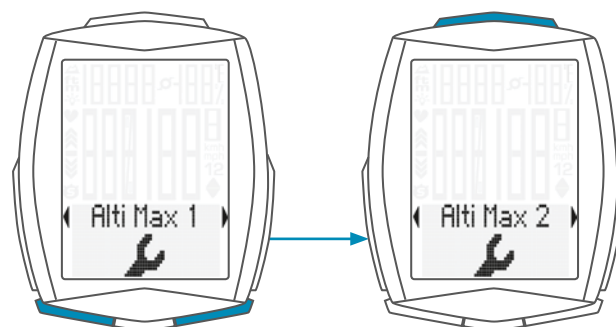

The setting display opens and the entry **digit flashes**.

Press the **BIKE** or **TPC** button to change the value of the digit.

Press the **SET** button to confirm your setting.

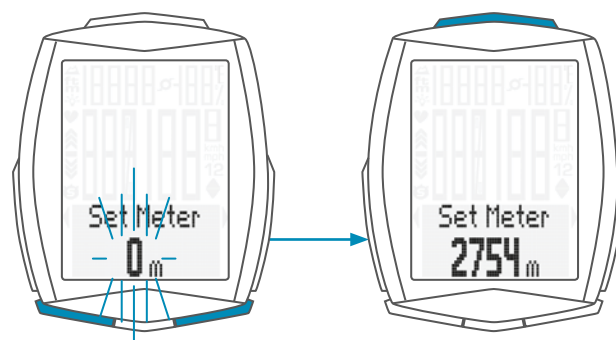

Settings – total values – maximum altitude

The response **“Set OK”** appears on the display.

If you want to configure further settings, press the **BIKE** or **TPC button** to access these.

If you do not want to configure any further settings, **press and hold the SET button**. The settings menu closes.

The VDO M6 returns to function mode.



Settings – total values – distance uphill

In the M6, you can set the distance travelled uphill separately for bike 1 and bike 2, for example at the start of the new cycling season.

ATTENTION: the M6 stores all total values even if you replace the batteries. No data is lost.

How to set the distance travelled uphill:

Press and hold the **SET** button until the settings menu opens.

Press the **BIKE** button to move from **Memory** to **Settings**.

Press the **SET** button to open the settings.

“**Language**” appears on the display.

Press the **BIKE** or **TPC** button to scroll to the settings for the **total values**.

Press the **SET** button to open the settings.

Press the **BIKE** or **TPC** button to scroll to the setting **Dist Up** (distance travelled uphill).

Press the **SET** button to open the settings.

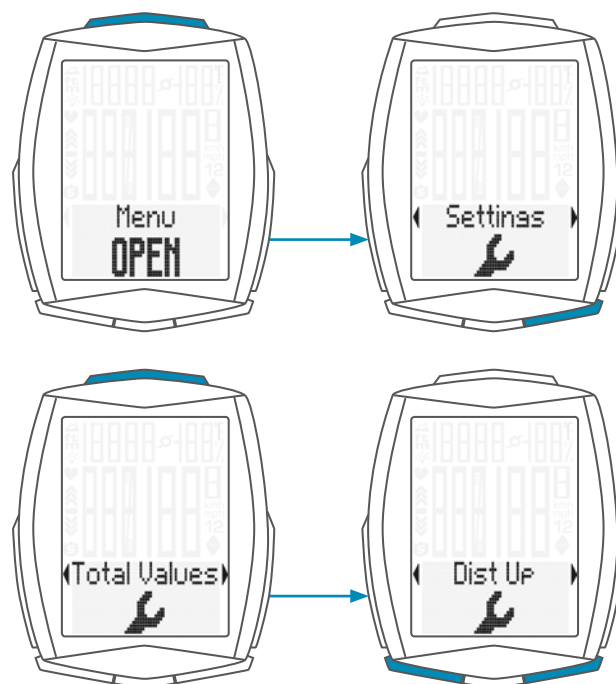

Press the **BIKE** or **TPC** button to select whether you want to configure the setting for **bike 1** or **bike 2**.

Press the **SET** button to confirm your selection and open the setting.

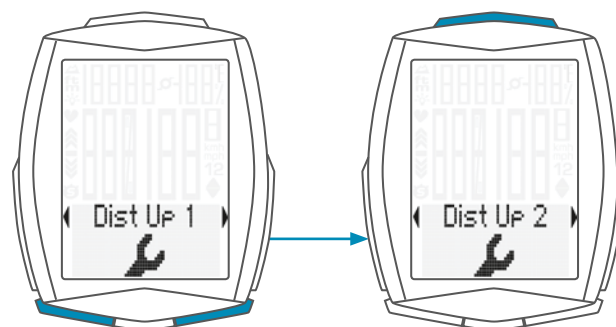

The **left digit flashes**. Press the **BIKE** or **TPC** button to set the value for this digit.

Press the **SET** button to confirm your setting.



Settings – total values – distance uphill

The **next digit** on the left starts to **flash** and is ready to be set.

Press the **BIKE** or **TPC button** to set the value for this digit.

Press the **SET button** to confirm your setting.

Once all the digits have been set, confirm the setting by pressing the **SET button**.



The response **“Set OK”** appears on the display.

If you want to configure further settings, press the **BIKE** or **TPC button** to access these.

If you do not want to configure any further settings, **press and hold the SET button**.

The settings menu closes.

The VDO M6 returns to function mode.



Settings – total values – distance downhill

In the M6, you can set the distance travelled downhill separately for bike 1 and bike 2, for example at the start of the new cycling season.

ATTENTION: the M6 stores all total values even if you replace the batteries. No data is lost.

How to set the distance travelled downhill:

Press and hold the **SET** button until the settings menu opens.

Press the **BIKE** button to move from **Memory** to **Settings**.

Press the **SET** button to open the settings.

“**Language**” appears on the display.

Press the **BIKE** or **TPC** button to scroll to the settings for the **total values**.

Press the **SET** button to open the settings.

Press the **BIKE** or **TPC** button to scroll to the setting **Dist Down** (distance travelled downhill).

Press the **SET** button to open the settings.

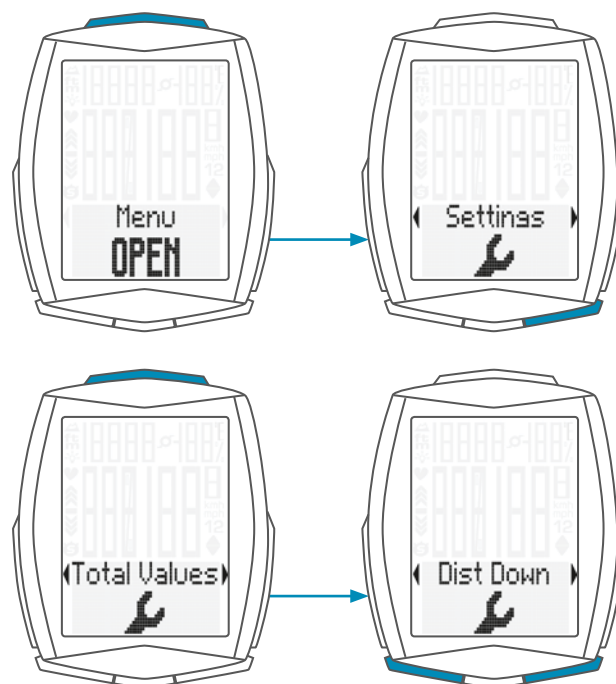

Press the **BIKE** or **TPC** button to select whether you want to configure the setting for **bike 1** or **bike 2**.

Press the **SET** button to confirm your selection and open the setting.

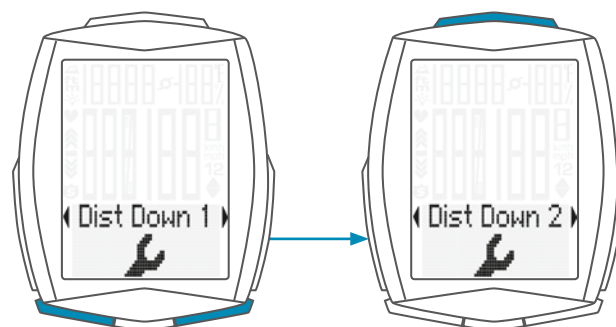

The **left digit flashes**. Press the **BIKE** or **TPC** button to set the value for this digit.

Press the **SET** button to confirm your setting.



Settings – total values – distance downhill

The **next digit** on the left starts to **flash** and is ready to be set.

Press the **BIKE** or **TPC button** to set the value for this digit.

Press the **SET button** to confirm your setting.

Once all the digits have been set, confirm the setting by pressing the **SET button**.

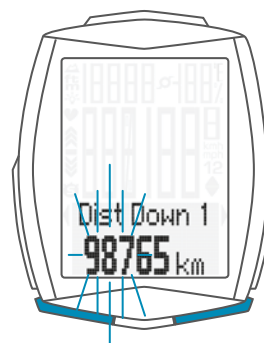

The response **“Set OK”** appears on the display.

If you want to configure further settings, press the **BIKE** or **TPC button** to access these.

If you do not want to configure any further settings, **press and hold the SET button**.

The settings menu closes.

The VDO M6 returns to function mode.



Settings – total values – total calorie burn

In the M6, the total calorie burn can be set for all trips, separately for bike 1 and bike 2, for example at the start of the new cycling season.

ATTENTION: the M6 stores all total values even if you replace the batteries. No data is lost.

How to set the total calorie burn:

Press and hold the **SET** button until the settings menu opens.

Press the **BIKE** button to move from **Memory** to **Settings**.

Press the **SET** button to open the settings.

“**Language**” appears on the display.

Press the **BIKE** or **TPC** button to scroll to the settings for the **total values**.

Press the **SET** button to open the settings.

Press the **BIKE** or **TPC** button to scroll to the setting **Total Kcal** (total calorie burn).

Press the **SET** button to open the settings.

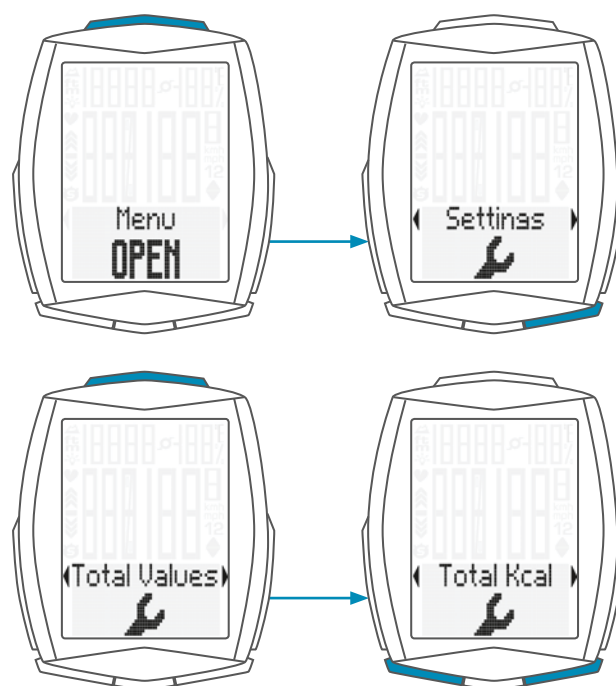

Press the **BIKE** or **TPC** button to select whether you want to configure the setting for **bike 1** or **bike 2**.

Press the **SET** button to confirm your selection and open the setting.

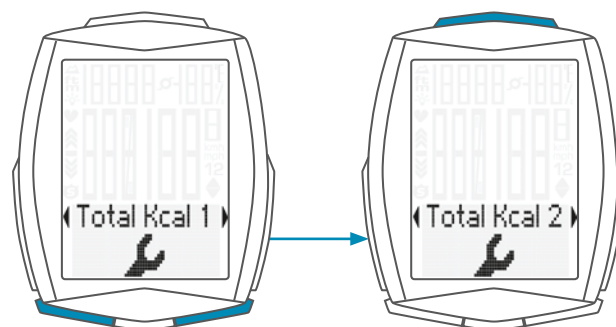

The **left digit flashes**. Press the **BIKE** or **TPC** button to set the value for this digit.

Press the **SET** button to confirm your setting.



Settings – total values – total calorie burn

The **next digit** on the left starts to **flash** and is ready to be set.

Press the **BIKE** or **TPC button** to set the value for this digit.

Press the **SET button** to confirm your setting.

Once all the digits have been set, confirm the setting by pressing the **SET button**.

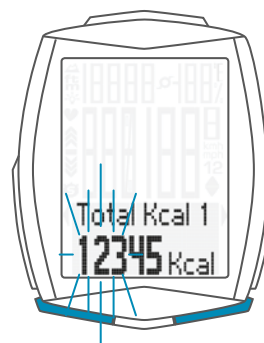

The response **“Set OK”** appears on the display.

If you want to configure further settings, press the **BIKE** or **TPC button** to access these.

If you do not want to configure any further settings, **press and hold the SET button**.

The settings menu closes.

The VDO M6 returns to function mode.



Settings – total values – resetting the total values

The M6 offers the opportunity to reset the total values to zero. Before the start of the new cycling season, you can therefore reset all your values for the year to zero.

How to reset the total values:

Press and hold the SET button until the settings menu opens.

Press the **BIKE button** to move from **Memory to Settings**.

Press the **SET button** to open the settings.
“Language” appears on the display.

Press the **BIKE** or **TPC button** to scroll to the settings for the **total values**.

Press the **SET button** to open the settings.
 Press the **BIKE** or **TPC button** to scroll to the setting **Totals Reset** (reset total values).

Press the **SET button** to open the setting.

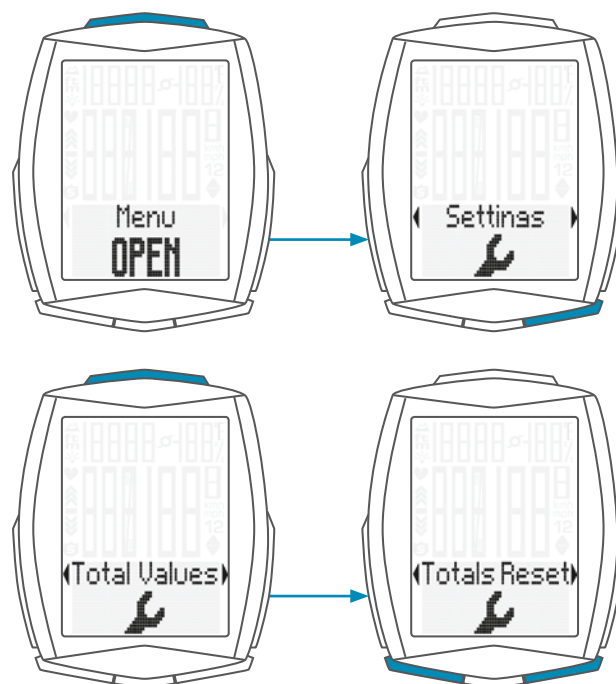

Totals Reset ‘No’ appears on the display.

Press the **BIKE button** to change the display text to **Totals Reset ‘Yes’**.

If you are sure that you want to reset the total values to zero, confirm “Yes” by pressing the SET button.

The total values are then reset to zero.

ATTENTION: this procedure CANNOT be undone.

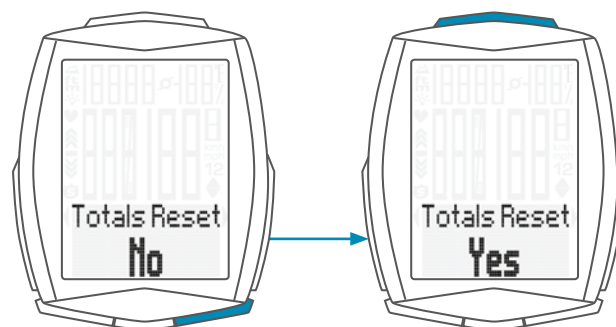

Settings – total values – resetting the total values

The response “**Totals Reset Done**” appears on the display.

If you want to configure further settings, press the **BIKE** or **TPC button** to access these.

If you do not want to configure any further settings, **press and hold the SET button**. The settings menu closes.

The VDO M6 returns to function mode.



Setting the navigator

The navigator is a second, completely independent trip distance counter.

The navigator can:

- be reset to zero any number of desired times during a trip
- be set to a distance value
- count forwards or backwards from the set distance value.

How to set the navigator:

Press the **BIKE button** to display the **navigator function**.



Once the navigator function is on the display, press and hold the **SET button** until the settings menu opens.



First select whether the navigator should count **forwards** or **backwards** from the set value.

Press the **BIKE button** to make the selection.

Press the **SET button** to confirm your selection.

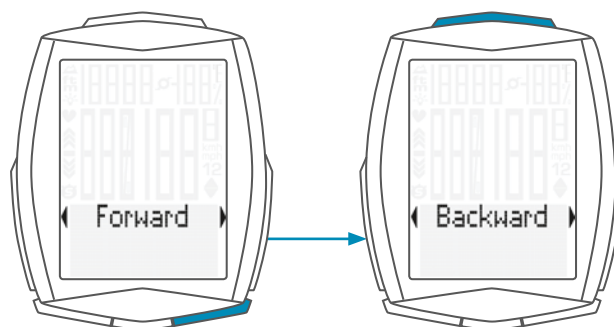

The screen for setting the navigator's distance value is opened. The **first digit on the left flashes**.

Press the **BIKE** or **TPC button** to change this digit.

Press the **SET button** to confirm the entry.

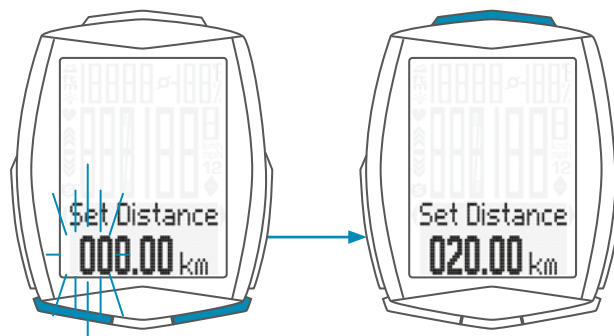

Setting the navigator

The **second digit on the left flashes**.
Press the **BIKE** or **TPC button** to change this digit.

Press the **SET button** to confirm the entry.



Once all the digits have been set, confirm the entry by pressing the **SET button**.

The response **“Set OK”** appears on the display.
The settings menu closes.

The VDO M6 returns to function mode.



Resetting the navigator to zero

The navigator can be reset to **ZERO** any number of desired times during a trip.

How to reset the navigator:

Press the **BIKE button** to display the **navigator function**.



Once the navigator function appears on the display, press and hold the BIKE button.

Navigator RESET appears on the display.

If you **continue to hold down the BIKE button**, the **navigator is reset to ZERO**.



Trip section counter

The VDO M6 has a time and distance counter that works similarly to a stopwatch.

When the trip section counter is running, the time and the distance covered in this time are recorded.

Starting the trip section counter

Simultaneously press the **BIKE** and **SET** buttons.

The **section time** immediately appears on the display and the **icon** for the **trip section counter** is visible.



Press the **BIKE** button to scroll to the trip section.



Stopping the trip section counter

To **stop** the **trip section counter**, **simultaneously** press the **BIKE** and **SET** buttons.

ATTENTION: if you take a break (speed = ZERO), the trip section counter will automatically stop.

When you set off again (the trip section counter is still active, as shown by the icon “**G**” on the display), the trip section counter will automatically run again.

Restarting the trip section counter

If you have manually stopped the trip section counter and now want to restart it, **simultaneously** press the **BIKE** and **SET** buttons again. The trip section counter continues from the last value.



Resetting the trip section counter to zero

To reset the counter **either** the **section time** or the **section distance** must be shown on the display.

Press and hold the BIKE button.

The text **Trip Section RESET** appears on the display.

If you **continue to hold down the BIKE button**, the **trip section data** is now reset to **zero**.

The following data is reset to zero:

- Section distance
- Section ride time



Resetting trip data after the trip

After each trip, you can reset the data for this trip to zero. The VDO M6 is then ready for the next trip.

ATTENTION: your total distance (total number of kilometres ridden), total ride time, total altitude and total calorie burn (with an activated heart rate option) are not reset to ZERO.

How to reset the trip data:

Press and hold the **BIKE button** for a few seconds.

The text **Tour Data RESET** appears on the display.

If you **continue to hold down the BIKE button**, the **trip data** is now reset to **zero**.

The following data is reset to zero:

- Distance
- Ride time
- Average speed
- Maximum speed
- Altitude gain/loss
- Distance uphill/downhill
- Maximum altitude on the trip
- Average gradient uphill/downhill on the trip
- Maximum gradient uphill/downhill on the trip
- Elevation profile for the trip



If the heart rate option is activated (see page 71):

- Average heart rate
- Maximum heart rate
- Time in, over and under the set training zone
- Calories
- Heart rate graph
- Intensity graph

If the cadence option is activated (see page 76):

- Average cadence
- Maximum cadence

Saving trip data

The M6 can save the data for a trip. Data for 10 trips can be saved. If the data memory is full with 10 trips, the first trip saved is deleted and overwritten with the new trip to be saved.

The following trip data is saved:

- Trip date
- Distance
- Ride time
- Average speed
- Maximum speed
- Minimum/maximum temperature
- Altitude gain/loss
- Distance uphill/downhill
- Maximum altitude
- Average gradient uphill/downhill
- Maximum gradient uphill/downhill

If the heart rate option is activated:

- Distribution of the heart rate values across the intensity zones
- Times in the intensity zones
- Calorie burn
- Average heart rate
- Maximum heart rate
- Time in/over/under the set training zone

If the cadence option is activated:

- Average cadence
- Maximum cadence

The save enquiry appears each time the trip data has been reset.

The following text appears on the display: **“Store Data YES”**.

Press the **SET button** to confirm that the trip data should be saved.



If you do **NOT** want to save the data, press the **BIKE button to select “NO”** and confirm this selection by pressing the **SET button**.

Once the trip data has (or has NOT) been saved, the M6 automatically returns to function mode.



Accessing the trip data from the memory

The M6 can store data from 10 trips.
This data can be accessed at any time.

How to access the trip data:

Press and hold the SET button until the menu opens:
Once the menu has opened **“Memory”** appears on the display.
Press the **SET button** to open the **memory**.



Press the **BIKE** or **TPC button** to scroll through the 10 stored trips.

Press the **SET button** to open the desired trip.
Press the **BIKE** or **TPC button** to scroll through the trip data.

Press and hold the **SET button** to return to function mode.



Bike selection: bike 1 or bike 2

The VDO M6 has an **automatic bike recognition function**.
The digital data from the speed transmitter also informs the VDO M6 of whether bike 1 or bike 2 is currently being used.
The total data is correspondingly stored for bike 1 or bike 2.

ATTENTION: when using the transmitter for the first time, the bike recognition switch must be set to either BIKE 1 or BIKE 2.

Only then will the automatic bike recognition work.

See Setting the transmitter on page 20.

Switching the backlight mode on or off

The M6 has a backlit display.

If backlight mode is activated, the display illuminates for several seconds each time a button is pressed.

If backlight mode is activated, the **light icon** can be seen at the top of the display.

ATTENTION: backlight mode is switched off if the M6 goes into sleep mode, e.g. if you take a break during a trip. This avoids unnecessary use of the battery.



How to switch ON the backlight mode:

Simultaneously press the **SET** and **TPC buttons**.
The text **“Light On”** and the light icon are displayed.

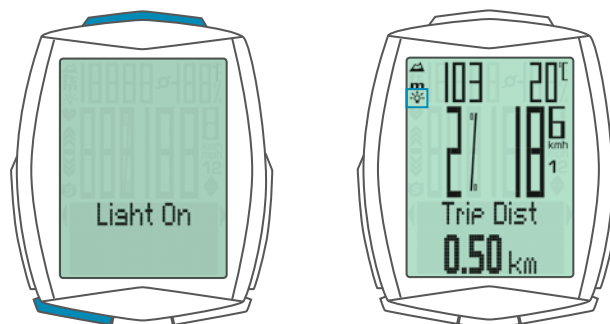

How to switch OFF the backlight mode:

Simultaneously press the **SET** and **TPC buttons**.
The text **“Light Off”** is displayed and the light icon disappears.



Activating the heart rate option

The M6 can also display heart rate values.

ATTENTION: the heart rate option can only be activated if you have the VDO heart rate transmitter, product no. CP3013.

How to activate the heart rate option:

Press and hold the **SET button** until the settings menu opens.

Press the **BIKE button** to move from **Memory to Settings**.

Press the **SET button** to open the settings.

“**Language**” appears on the display.

Press the **BIKE** or **TPC button** to scroll to the settings for the **Sensor**.

Press the **SET button** to open the settings for the sensors.

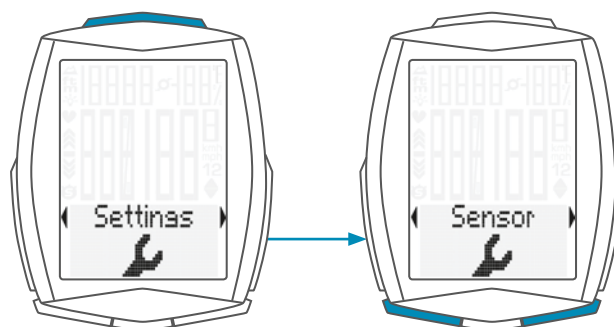

“**Heart Rate OFF**” flashes on the display.

Press the **BIKE button** to select **ON**.

Press the **SET button** to confirm the selection.

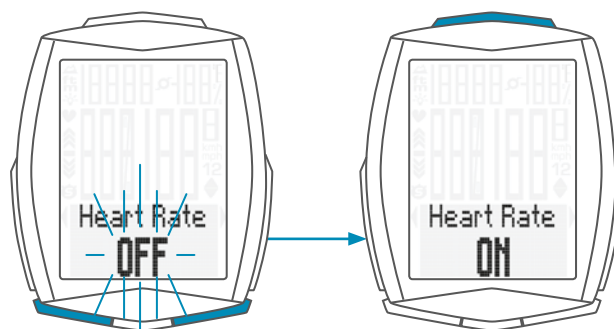

The selection is confirmed on the display with the text **SET OK**.

The heart rate option is now activated.

Press and hold the **SET button** to return to function mode.



Display when using the heart rate option

If the heart rate option is activated, the current heart rate is shown on the left of the display.

If the **heart rate option is activated** the indicator arrows show whether the heart rate is below or above the selected training zone.



The current gradient uphill/downhill, which is displayed at this point if the heart rate option is not activated, is now shown at the top right of the display.

The temperature can now be accessed via the menu within the bike functions by pressing the **BIKE** button.



Button allocation with the heart rate option

If the heart rate option is activated, the heart rate functions can be accessed by pressing the TPC (TOTAL/PULSE/CAD) button.

When the heart rate option is activated, the TPC (TOTAL/PULSE/CAD) button has the following functions:

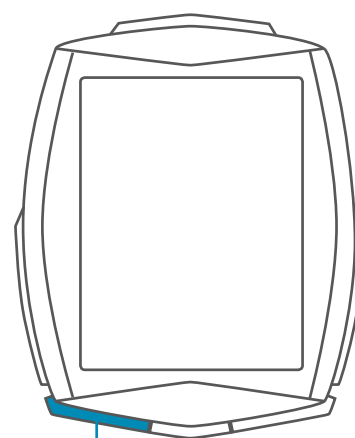

TPC (TOTAL/PULSE/CAD)

In function mode:

- Access the heart rate functions (scroll forwards through the functions)
- Select the heart rate training zone (press and hold)

In setting mode:

- Scroll in the setting menu (backwards)
- Change the data to be set (decrease)

Functions in the heart rate option

If the heart rate option is activated, the heart rate functions are accessed by pressing the TPC (TOTAL/PULSE/CAD) button.

The following functions can be sequentially accessed:

Heart rate graph

Displays the heart rate progress for the current trip over the last 10-15 minutes.



Zones graph

With current heart rate as a percentage of the personal maximum heart rate and an indicator of the selected training zone (FIT/FAT/OWN).



Intensity zones graph

Indicates the percentage shares of the four pre-defined intensity zones during the training.

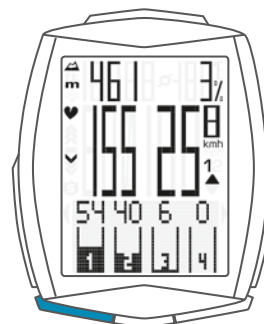

Calories

Indicates the calories burnt on the current trip.



Average heart rate

Indicates the average heart rate on the current trip.

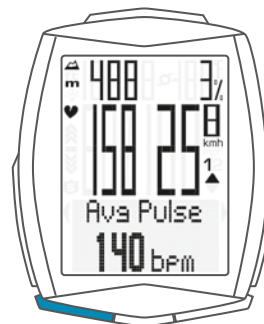

Functions in the heart rate option

Maximum heart rate

Indicates the maximum heart rate on the current trip.



Time below

the selected training zone.

Indicates the time during which the current heart rate was under the lower limit for the training zone.



Time in

the selected training zone.

Indicates the time during which the current heart rate was within the selected training zone.



Time above

the selected training zone.

Indicates the time during which the current heart rate was above the upper limit for the training zone.



Selecting the heart rate training zone

If the heart rate option is activated, you can choose between three training zones:

Training zone FAT

Select this training zone if you want to promote optimum fat burning while training.

Lower limit: 55 percent of the HR max

Upper limit: 70 percent of the HR max

Training zone FIT

Select this training zone if you want to enhance your general fitness.

Lower limit: 70 percent of the HR max

Upper limit: 80 percent of the HR max

Training zone OWN

Select this training zone if you have defined your own training target.

You can set the lower and upper limits in the settings under **MY DATA**.

Based on the calculated or set HR max, the calculated or set lower and upper limits for the respective training zone will appear on the display.

Press the **BIKE** or **TPC button** to select one of the three training zones.

Press the **SET button** to confirm the selection.

The VDO M6 confirms your selection by displaying the text **Set OK**.

The M6 automatically returns to function mode.

How to select the heart rate training zone:

Press and hold the TPC (TOTAL/PULSE/CAD) button until the **heart rate zone** selection menu opens.

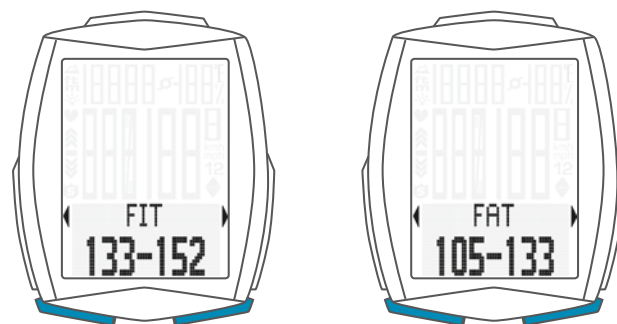

Activating the cadence option

The VDO M6 can also display the cadence.

ATTENTION: to display the cadence, the VDO cadence transmitter, product no. CP3012, must be installed.

The cadence option must be activated in the settings.

How to activate the cadence option:

Press and hold the SET button until the settings menu opens.

Press the **BIKE button** to move from **Memory to Settings**.

Press the **SET button** to open the settings.

“Language” appears on the display.

Press the **BIKE** or **TPC button** to scroll to the settings for the **SENSOR**.

Press the **SET button** to open the setting for the sensors.

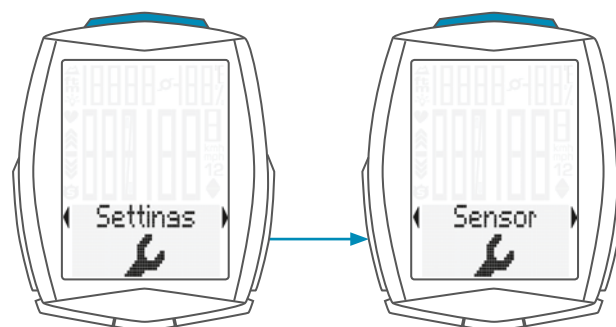

Press the **SET button** to confirm **Heart Rate OFF**.

You can now press the **BIKE button** to activate the cadence.

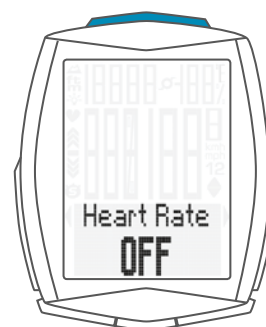

Press the **Bike button** to switch from **OFF to ON**.

Press the **SET button** to confirm your selection.
The cadence option is now activated.

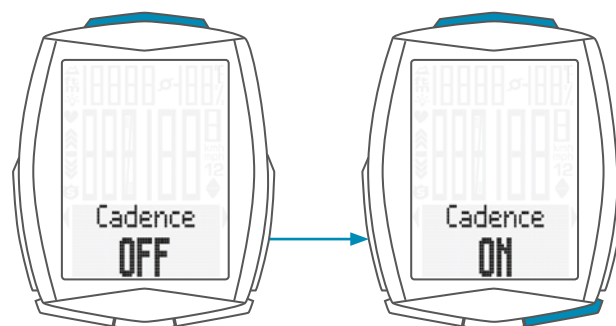

Activating the cadence option

The VDO M6 confirms the setting by displaying the text **SET OK**.

If you want to configure further settings, press the **BIKE** or **TPC button** to access these.

If you do not want to configure any further settings, **press and hold the SET button**. The settings menu closes.

The VDO M6 returns to function mode.



Display when using the cadence option

If the cadence option is activated, the current cadence is shown at the top right of the display.

The **temperature indicator** can now be found in the **BIKE function menu**.

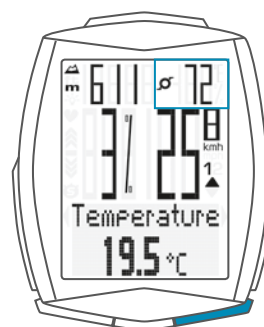

Button allocation and functions with the cadence option

If the cadence option is activated, the cadence functions are displayed by pressing the TPC (TOTAL/PULSE/CAD) button.

Current cadence:

Permanently shown on the top right of the display.

Average cadence CAD AVG:

The average cadence for the current trip is displayed.



Maximum cadence CAD MAX:

The maximum cadence for the current trip is displayed.



Attaching the cadence transmitter

A description of how to attach the cadence transmitter can be found in the cadence transmitter instruction manual.

A video of how to attach the cadence transmitter can be found at: www.vdocyclecomputing.com/service

Heart rate + cadence option

On the VDO M6, you can **simultaneously** activate the heart rate and cadence options.

The heart rate and cadence are both shown on the display simultaneously.

For how to activate the heart rate option, see page 71.

For how to activate the cadence option, see page 76.

Display with heart rate + cadence

If both the heart rate and cadence options are activated both values are simultaneously shown on the display.

The current heart rate is shown on the left of the middle line instead of the gradient uphill/downhill as a percentage.

The cadence is displayed on the top right instead of the temperature.



The gradient uphill/downhill as a percentage can be viewed by pressing the **ALTI button**.



The temperature can now be accessed by pressing the **BIKE button**.



Button allocation/functions with the heart rate + cadence options

All heart rate and cadence functions are accessed by pressing the TPC (TOTAL/PULSE/CAD) button.

A description of the heart rate functions can be found on page 73.

A description of the cadence functions can be found on page 78.

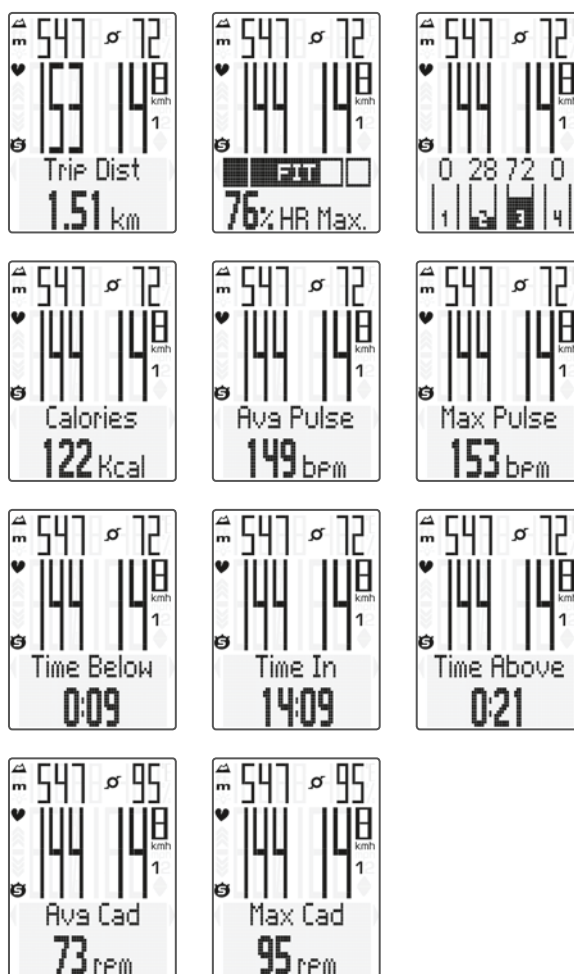

Replacing the battery in the computer

To ensure your cycle computer is fully functional, we recommend **replacing the battery annually**.

ATTENTION: your settings, total distance and total ride time information remain stored when you replace the battery. **NO** data is lost.

You need a 3 V 2450 battery.
We recommend using a branded battery from Sony, Panasonic, Varta or Duracell.

How to replace the battery:

STEP 1

Use a coin to remove the battery compartment cover.

STEP 2

Remove the dead battery.

ATTENTION: Wait for 10 seconds before inserting the new battery. The electronics need this time to recognise that the battery is being changed.

STEP 3

Insert the battery into the computer housing with the +pole up. Ensure that the battery is not tilted. Ensure that the rubber seal lies smoothly on the lid of the battery compartment.

STEP 4

Insert the battery compartment cover into the opening and use a coin to turn it to right as far as it will go.

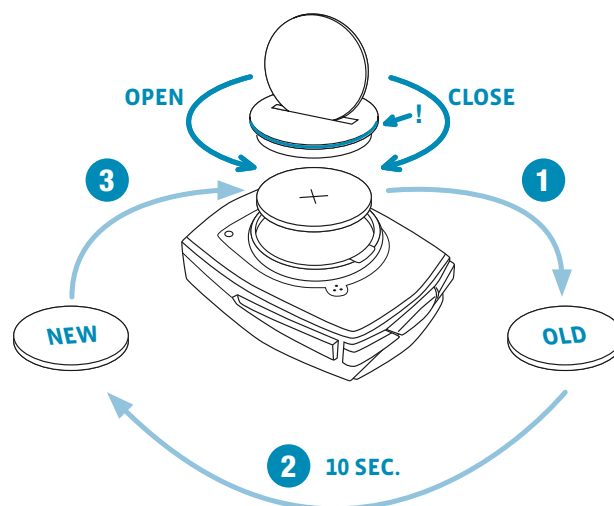

Replacing the battery in the speed transmitter

The battery in the speed transmitter **should be replaced annually** to guarantee seamless wireless transmission.

You need a 3 V 2032 battery.
We recommend using a branded battery from Sony, Panasonic, Varta or Duracell.

How to replace the battery:

STEP 1

Use a coin to remove the battery compartment cover.

STEP 2

Remove the dead battery.

ATTENTION: Wait for 10 seconds before inserting the new battery. The electronics need this time to recognise that the battery is being changed.

STEP 3

Insert the battery into the transmitter housing with the +pole up. Ensure that the battery is not tilted. Ensure that the rubber seal lies smoothly on the lid of the battery compartment.

STEP 4

Insert the battery compartment cover into the opening and use a coin to turn it to right as far as it will go.

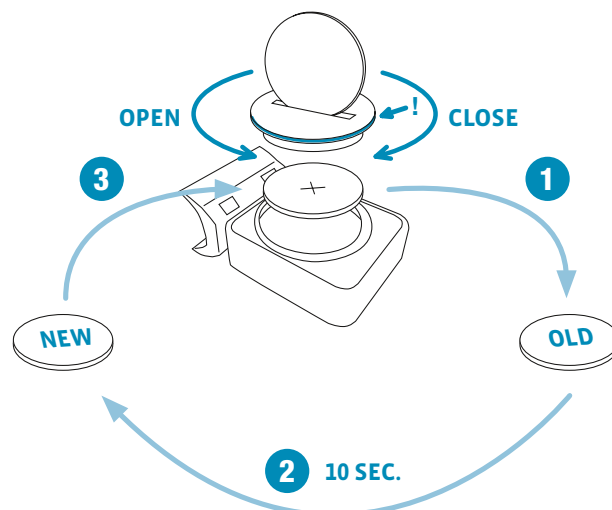

Terms of guarantee

VDO Cycle Parts offers a **2-year guarantee** on your VDO computer, **starting from date of purchase**. This guarantee covers material and processing defects on the computer itself, the sensor/transmitter and the handlebar bracket. Cables, batteries and mounting materials are not covered by the guarantee.

The guarantee is only valid if the affected components have not been opened (exception: computer's battery compartment), no force has been used and there is no sign of wilful damage.

Please store the purchase receipt in a safe place as it must be submitted in the event of a complaint.

If your complaint is legitimate, you will receive a comparable replacement device. You are not entitled to a replacement of the identical model if the model in question is no longer in production due to a model change.

Please contact the dealer from whom you purchased the device for all complaints and guarantee claims. Alternatively, send your complaint directly to:

Cycle Parts GmbH

Le Quartier Hornbach 13
67433 Neustadt/Weinstrasse

If you have any technical questions, please do not hesitate to call our hotline on:

+49 (0) 63 21- 95 82 7 - 10

+49 (0) 63 21- 95 82 7 - 18

**Our telephone hotline is available to assist you
between the hours of
9:00-12:00, Monday to Friday
service@cycleparts.de**

Additional technical information is available at:
www.vdocyclecomputing.com

We reserve the right to make technical changes in the course of further development.

Troubleshooting

| Error | Possible cause | Correction |
|--|---|---|
| Half segments on the display (e.g. after a battery change) | Computer software not running correctly after battery change | Remove and re-insert the battery |
| No speed displayed | Distance from sensor to magnet too great or magnet not correctly aligned with the sensor position | Correct the sensor and magnet positions |
| No speed displayed | Computer not properly clicked into the handlebar bracket | Insert the computer into the handlebar bracket and rotate it as far as possible ("click") |
| No speed displayed | Wheel circumference is not correctly set or is at zero | Set the wheel circumference |
| No speed displayed | Battery in the transmitter is dead | Replace the battery in the transmitter |
| Display becomes weak | Battery dead | Check the battery, replace if nec. |
| No heart rate displayed | Heart rate sensor has not been selected. | Select the heart rate sensor from the sensor selection area |
| No heart rate displayed | Heart rate sensor has not been paired | Activate the heart rate sensor, correctly position the heart rate chest belt on your body. Insert the computer into the handlebar bracket, heart rate symbol flashes to indicate pairing |
| No heart rate displayed | Battery in the heart rate chest belt is dead | Replace the battery in the heart rate chest belt |
| No cadence displayed | Cadence sensor has not been paired | Activate the cadence sensor, insert the computer into the handlebar bracket, cadence symbol flashes to indicate pairing |
| No cadence displayed | Battery in the cadence transmitter is dead | Replace the battery in the cadence transmitter |

Technical specifications

Computer:

Approx. 49 H x 38 W x 12 D mm

Display:

H approx. 39 mm, W approx. 29 mm

Computer weight:

Approx. 30 g

Handlebar bracket weight:

Approx. 10 g

Speed transmitter weight:

Approx. 20 g

Cadence transmitter weight:

Approx. 20 g

Heart rate transmitter weight:

Approx. 50 g

Computer battery:

3V, type 2450

Computer battery service life:

Approx. 2 years (approx. 400 ride hours, approx. 8,000 km (5,000 mi))

Speed transmitter battery:

3V, type 2032

Speed transmitter battery life:

Approx. 1.5 years (approx. 1,000 ride hours, approx. 20,000 km (12,000 mi))

Cadence transmitter battery:

3V, type 2032

Cadence transmitter battery life:

Approx. 1.5 years (approx. 1,000 ride hours, approx. 20,000 km (12,000 mi))

Heart rate transmitter battery:

3V, type 2032

Heart rate transmitter battery life:

Approx. 1.5 years (approx. 1,000 ride hours, approx. 20,000 km (12,000 mi))

Wireless transmission ranges:

Speed transmitter: 75 cm

Cadence transmitter: 90 cm

Heart rate transmitter: 75 cm

Temperature indicator range on the display:

-20°C to +70°C/ -4°F to +158°F

Speed range for wheel size 2,155 mm:

Min 2.0 km/h,

Max 199 kmh

Ride time measurement range:

Up to 99:59:59 HH:MM:SS.

Trip distance odometer measurement range:

Up to value 9,999.99 km or mi

NAVIGATOR measurement range:

From -99.99 to +999.99 km or mi

Total km measurement range:

Up to value 99,999 km or mi

Total ride time measurement range:

9999:59 HHHH:MM

Heart rate measurement range:

40 to 240 bpm

Cadence measurement range:

20 to 180 rpm

Wheel circumference setting range:

From 100 mm to 3,999 mm (3.9 to 157.4 inches)

Altitude measurement range:

-999 m to +4,999 m/-999 ft to 16,999 ft

Correct disposal of this product (electrical waste)



(To be used in EU countries and other European countries with a separate collection system). The labelling on the product and the relevant literature indicates that it must not be disposed of with normal household waste at the end of its service life. Please dispose of this device separately to other waste so as not to harm the environment or human health through uncontrolled waste disposal. Recycle the device to promote the sustainable reuse of material resources. Private users should contact the retailer from whom they purchased the product or the responsible

authorities to find out how they can recycle the device in an environment-friendly manner. Commercial users should contact their suppliers and consult the conditions of the sales agreement. This product must not be disposed of with other commercial waste.

EU declaration of conformity

We, CYCLE PARTS GmbH, Le Quartier Hornbach 13, D-67433 Neustadt/Weinstraße, declare that when used as intended, the VDO cycle computer with wireless transmission VDO M6 and all transmitters D3-SPD, D3-CAD, D3-HR comply with the essential requirements established in Article 3 of the R&TTE Directive 1999/5/EC.

The declaration of conformity can be viewed at: www.vdocyclecomputing.com.



Neustadt, October 2013

FCC-Addendum

This device complies with part 15 of the FCC Rules. Operation is subject to the following two conditions:

- (1) This device may not cause harmful interference, and
- (2) this device must accept any interference received, including interference that may cause undesired operation.

NOTE: This equipment has been tested and found to comply with the limits for a Class B digital device, pursuant to part 15 of the FCC Rules. These limits are designed to provide reasonable protection against harmful interference in a residential installation. This equipment generates, uses and can radiate radio frequency energy and, if not installed and used in accordance with the instructions, may cause harmful interference to radio communications. However, there is no guarantee that interference will not occur in a particular installation.

If this equipment does cause harmful interference to radio or television reception, which can be determined by turning the equipment off and on, the user is encouraged to try to correct the interference by one or more of the following measures:

- Reorient or relocate the receiving antenna.
- Increase the separation between the equipment and receiver.
- Connect the equipment into an outlet on a circuit different from that to which the receiver is connected.
- Consult the dealer or an experienced radio/TV technician for help.

Changes or modifications not expressly approved by the party responsible for compliance could void the user's authority to operate the equipment.

IC-Addendum

This device complies with Industry Canada licence-exempt RSS standard(s).

Operation is subject to the following two conditions:

- (1) This device may not cause interference, and

- (2) this device must accept any interference, including interference that may cause undesired operation of the device.

This Class digital apparatus complies with Canadian ICES-003.



Cycle Parts GmbH

Le Quartier Hornbach 13

67433 Neustadt/Weinstrasse (Germany)

+49 (0) 63 21- 95 82 7 - 0

www.vdocyclecomputing.com